



tSLC-2000

Visual Acuity Chart System



Operating Instructions for Visual Acuity Chart System TSLC-2000

Rev. 9

Language - English (EN)



SCIENCETERA Co., Ltd.



SCIENCETERA

Index

1 General information.....	1
1.1 Device Outline	1
1.2 Device name and model	1
1.3 Manufacturer	1
1.4 Qualification of the product as a medical device	2
1.4.1 Rationale for qualification	2
1.4.2 Not an accessory	3
1.4.3 Classification and regulatory implication.....	3
1.5 Device classification and justification	3
1.5.1 Risk class.....	3
1.5.2 Justification for classification	3
1.5.3 Non applicability of other rules	4
1.6 Regulatory mark	5
1.7 Authorised Representative in EU.....	5
2 Information.....	6
2.1 Intended purpose.....	6
2.2 Intended environment.....	6
2.3 Intended user	7
2.3.1 Segmentation of occupation	7
2.3.2 User characteristics.....	7
2.4 Residual risks	7
2.5 Indications	8
2.6 Contra-indications.....	8
2.7 Patient target groups	8
2.8 Undesirable side-effects	9
2.9 Operating principle	9
2.9.1 Mode of action	9

2.9.2 Scientific basis	9
3 Safety information	11
3.1 Reporting of Serious Incidents	14
4 Device description	15
4.1 Main body	15
4.2 Remote-control	17
4.3 Accessories	28
5 Installation	29
5.1 Installation of wall mount bracket	29
5.2 Wiring	34
5.3 Preparation of remote-control	35
6 Label and symbols	36
6.1 Main body	37
6.2 Remote-control	38
6.3 Power supply - Adapter	39
7 Preparation	40
7.1 Booting	40
7.2 Preset function in MENU screen	41
8 Operation	49
8.1 General visual acuity test	49
8.2 Astigmatism test	52
8.3 Duo-chrome	55
8.4 Phoria test	56
8.5 Color blindness test	59
8.6 ETDRS	64
8.7 Contrast sensitivity	65
9 Program function	66
9.1 Set	66
9.2 Use	68

10 Slide function	69
11 Maintenance	70
11.1 Malfunction warnings	70
11.2 Troubleshooting	71
11.3 Environmental & external influence precautions	72
11.4 Contra-indications & limitations of use	72
11.5 Biological, radiation, and material safety	72
11.6 Safe disposal information	73
11.7 Cleaning	73
11.8 Minimum hardware, network, and IT security requirements	74
11.8.1 Hardware requirements	74
11.8.2 IT Network requirements	74
11.8.3 IT security measures	74
12 Transport and storage conditions	75
13 Detailed specifications	76
13.1 General	76
13.2 Display pixel defect acceptance criteria	77
13.2.1 Definitions	77
13.2.2 Acceptance criteria	78
13.2.3 Test Conditions	79
13.2.4 Rationale for criteria	79
13.2.5 Field service / Post-Market handling	79
14 Regulatory and compliance information	80
15 EMC information	82
16 Revision history	84

1 General information

1.1 Device Outline

The Visual Acuity Chart System Model TSLC-2000 is a chart presenting device that displays the charts on the LCD display panel. This medical device is controlled by a remote-control and external devices such as digital refractor, tablet and personal computer.

- Test distance can be set in the range of 1.5 to 8 meters in 0.1 meters increments (4.75 to 26 ft in 0.25 ft increments). The chart size is reduced or enlarged corresponding the set test distance to maintain the same visual angle.
- Charts of the same visual acuity can be changed at random. It prevents erroneous test result from the patient memorizing the charts.
- The 24 inches large and wide screen allows 0.03 VA (20/660, 6/200) visual acuity to be displayed.
- Images or slides can be displayed as an alternative to test charts.
- The charts can be displayed while the contrast is decreased to test the visual acuity under low-contrast conditions.

1.2 Device name and model

- Device name: Visual Acuity Chart System
- Model: TSLC-2000
- Rating: 100-240 V~, 50/60 Hz, 50 VA
- Software: Android 9.0.0
- Serial Number: See Marking plate. (Refer to 6.1 Main body)

1.3 Manufacturer

SCIENCETERA Co., Ltd.

B1602, 302, Galmachi-ro Jungwon-gu Seongnam-si Gyeonggi-do 13201 KOREA

Phone +82-31-778-8670

1.4 Qualification of the product as a medical device

– *in accordance with MDR Annex II Section 1.1 (e)*

1.4.1 Rationale for qualification

The Visual Acuity Chart System is qualified as a medical device under Regulation (EU) 2017/745, Article 2 (1), which defines a medical device as:

'medical device' means any instrument, apparatus, appliance, software implant, reagent, material or other article intended by the manufacturer to be used, alone or in combination, for human beings for one or more of the following specific medical purposes:

- diagnosis, prevent, monitoring, prediction, prognosis, treatment or alleviation of disease,
- diagnosis, monitoring, treatment, alleviation of, or compensation for, an injury or disability,
- investigation, replacement or modification of the anatomy or of a physiological or pathological process or state,
- providing information by means of in vitro examination of specimens derived from the human body, including organ, blood and tissue donations,

and which does not achieve its principal intended action by pharmacological, immunological or metabolic means, in or on the human body, but which may be assisted in its function by such means.

The following products shall also be deemed to be medical devices:

- devices for the control or support of conception;
- product specifically intended for the cleaning, disinfection or sterilization of devices as referred to in Article 1 (4) and of those referred to in the first paragraph of this point.

The device is intended to be used by ophthalmologists, optometrists, and other eye-care professionals to display standardized optotypes and test charts for diagnosis and monitoring of visual acuity, which is a key parameter in the evaluation of eye diseases and vision disorders.

Therefore, its intended purpose directly supports a diagnostic medical function, even though the device itself is non-invasive and does not act on the human body.

1.4.2 Not an accessory

The device is not merely an accessory under Article 2 (2) of the MDR, as it is not designed to enable another medical device to be used in accordance with its intended purpose, nor to specifically and directly assist a medical device in its medical function. It performs an independent diagnostic role by providing optotypes for vision testing.

1.4.3 Classification and regulatory implication

Based on its intended purpose and non-invasive nature, the device is classified as:

Medical device, Class I (non-invasive) according to MDR Annex VIII, Chapter III, Rule 13

1.5 Device classification and justification

– in accordance with MDR Annex II Section 1.1 (f)

1.5.1 Risk class

The Visual Acuity Chart System is a non-invasive active medical device intended to be used by ophthalmologists, optometrists, and other eye-care professionals for the diagnosis and assessment of visual function. Accordingly, the device classified as Class I, in accordance with MDR Annex VIII, Chapter III, Rule 13.

1.5.2 Justification for classification

1.5.2.1 Applicable rule

MDR Annex VIII, Chapter III Classification Rules 6. ACTIVE DEVICES 6.5. Rule 13 Other active devices are classified as class I

1.5.2.2 Rationale

- a) The device is an active device, since it uses electrical energy to display optotypes on an electronic screen.
- b) It does not transfer energy to the human body, nor does it measure or monitor any physiological parameters.
- c) The device merely provides optical visual stimuli for vision testing and does not interact with the human body in any hazardous way.
- d) As it does not meet the conditions described in Rules 9 to 12 and poses a very low risk to patients, it falls into the residual category under Rule 13 and is therefore classified as Class I.

1.5.3 Non applicability of other rules

No.	Rule summary	A or N/A	Reason for non-applicability
Rule 9	Active devices intended to deliver energy to or exchange energy with the human body for diagnosis or therapy	N/A	The device does not deliver or exchange energy with the body
Rule 10	Active devices intended for monitoring or measurement of vital physiological parameters	N/A	The device performs no measurement or monitoring
Rule 11	Software intended for processing or interpretation of medical data	N/A	Built-in software only controls visual display; no diagnostic data processing
Rule 12	Active devices intended to emit or exchange energy absorbed by the body	N/A	The device emits only visible light for visual perception, not for absorption or treatment
Rule 13	All other active devices not covered by the above rules	A	Non-invasive, non-measuring, active visual display device

1.6 Regulatory mark

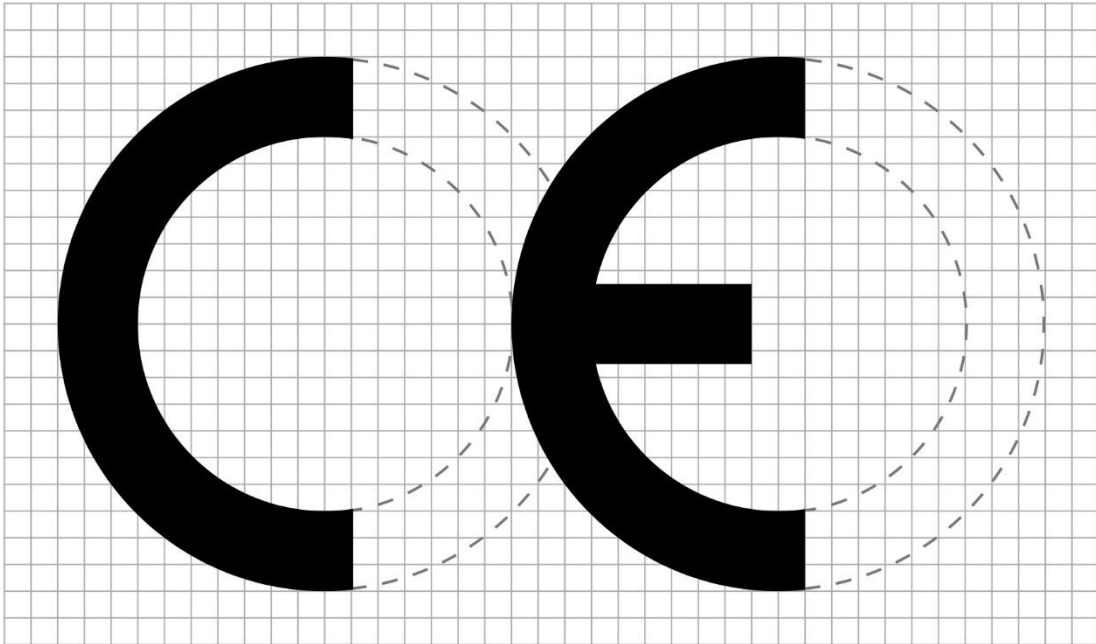

[REGULATION (EU) 2017/745 – ANNEX V CE MARKING OF CONFORMITY]

1.7 Authorised Representative in EU

Advena Ltd.

Tower Business Center, 2nd Flr.,

Tower Street Swatar BKR 4013 Malta



2 Information

2.1 Intended purpose

To display visual acuity test images on a screen for the purpose of patient's eyesight test.

2.2 Intended environment

Item	Description
Location	Specialized medical institutions such as medical offices, refraction room, etc. in hospitals
Lighting	Indoor lighting 80 to 320 cd/m ² 200 cd/m ² recommended
Noise	Used in relatively quiet conditions to allow conversation with the patients
Space	A certain distance from the patient must be ensured – at least 1.5m
Power supply	AC 100-240V 50/60Hz fixed outlet required
Buildings or infrastructures	Professional healthcare facility environment Hospitals, medical institutions, and treatment facilities; Hospitals except for near active HF surgical equipment and the RF shielded room of an ME system for magnetic resonance imaging
Operating environment	Temperature: -10 °C to +40 °C Humidity: 10 to 90 % (non-condensing) Atmospheric pressure: 80 kPa to 106 kPa

	This device is intended for use only in professional healthcare facility environments, such as hospitals, clinics, and optometry offices. Do not use in non-clinical or home environments.
	Do not operate this device in close proximity to active high-frequency (HF) surgical equipment, as excessive electromagnetic interference (EMI) may cause malfunction or incorrect chart display.
	This device must not be used inside or adjacent to the RF shielded room of an ME system for magnetic resonance imaging (MRI). Strong electromagnetic fields in such environments can lead to device failure and potential hazards.

2.3 Intended user

2.3.1 Segmentation of occupation

User group	Description
Doctor	A doctor who tests, diagnoses and prescribes a patient's vision in hospital
Optometrist	Specialized medical technician who specializes in eyesight test in hospitals, etc.
Optician	A medical technician who performs an eyesight test for prescription of eyeglasses or contact lenses
medical professional, technician or relevant qualifying holder	A person who assists the test according to the doctor's instructions

2.3.2 User characteristics

- healthcare qualified professionals with relevant qualifications
- a secondary level of education, at least
- receive minimal training or instruction before using the product
- possibility of elderly users or user unfamiliar with digital devices

2.4 Residual risks

- Temporary eye fatigue or discomfort due to prolonged viewing of digital visual acuity charts.
- Possible discomfort for individuals who are sensitive to bright or high-contrast displays.

2.5 Indications

The device is indicated for patients requiring:

- Assessment of visual acuity due to refractive errors (myopia, hyperopia, astigmatism)
- Monitoring visual function in conditions affecting central vision
- Pre- and post-examination assessment during refraction procedures
- Evaluation of binocular vision, phoria, stereopsis, and contrast sensitivity (when applicable charts are selected)

It is intended for use in clinical environments such as ophthalmology clinics, optometry offices, optical shop, and hospital refraction rooms.

2.6 Contra-indications

There are no known absolute contraindications for the use of this device. However, use should be avoided or performed with caution in the following cases:

- Patients with photosensitive epilepsy or a history of light-induced seizures
- Patients who cannot maintain stable fixation or cannot understand displayed optotypes
- Patients with severe cognitive impairment preventing meaningful response
- Patients who experience discomfort due to bright digital displays

If any unusual symptoms (e.g., dizziness, visual discomfort) occur, testing shall be discontinued.

2.7 Patient target groups

The device is intended for:

- Adults and children capable of recognizing visual test symbols
- Patients with refractive errors or general ophthalmic conditions requiring visual acuity assessment
- Patients capable of following simple instructions and responding to visual stimuli

The device is not intended for unconscious patients, infants unable to respond, or patients requiring objective automated vision assessment.

2.8 Undesirable side-effects

No undesired physiological side effects are known or expected from the use of this device. Information regarding these considerations should be conveyed to the patient when necessary.

2.9 Operating principle

The Visual Acuity Chart System operates by displaying optotypes (letters, numbers, symbols, or figures) on an electronic display to assess a patient's visual acuity at defined distance. The device uses an Android-based software application running on an integrated display module that generates calibrated visual stimuli in accordance with standard visual-acuity testing method (e.g., Tumbling E, Landolt ring, Numbers). The optotypes are scaled according to the testing distance (1.5m to 8 m) to correspond to specific visual-acuity levels (e.g., 1.0, 0.8, 0.5, etc.).



2.9.1 Mode of action

The system does not act on or interact with the human body. Its mode of action is purely visual presentation of stimuli for subjective assessment of vision. It provides optical images on a display; the human eye perceives these images, and the examiner interprets the patient's response. There is no energy transfer, no diagnostic measurement, and no physiological effect generated by the device itself.













2.9.2 Scientific basis













The principle is based on established ophthalmic science for visual-acuity determination, as standardized in:

















- ISO 8596:2017 – Ophthalmic optics – Visual acuity testing – standard and clinical optotypes and their presentation
- ISO 10938:2016 – Ophthalmic optics – Chart displays for visual acuity measurement – Printed, projected and electronic





	This device shall be operated only by quality healthcare professionals with appropriate training in visual acuity testing procedures.
	Elderly users or those unfamiliar with digital devices may require additional instruction or supervised use to avoid operational errors.
	The device is not intended for patient self-testing or layperson use. Any use outside the defined professional user group may compromise patient safety and test reliability.

3 Safety information

	Use only with IEC 60601-1 compliant power supply – adapter.
	Do not expose the device to moisture or liquids – risk of electric shock or fire
	Ensure proper test distance (e.g., 5 m / 13 ft) between screen and patient’s eye.
	Not for home use or self-diagnosis by patients.
	Do not operate in the presence of flammable anesthetic gases.
	This device is intended for use only in professional healthcare facility environments, such as hospitals, clinics, and optometry offices. Do not use in non-clinical or home environments
	Do not operate this device in close proximity to active high-frequency (HF) surgical equipment, as excessive electromagnetic interference (EMI) may cause malfunction or incorrect chart display.
	This device must not be used inside or adjacent to the RF shielded room of an ME system for magnetic resonance imaging (MRI). Strong electromagnetic fields in such environments can lead to device failure and potential hazards.
	This device shall be operated only by quality healthcare professionals with appropriate training in visual acuity testing procedures.
	Elderly users or those unfamiliar with digital devices may require additional instruction or supervised use to avoid operational errors.
	The device is not intended for patient self-testing or layperson use. Any use outside the defined professional user group may compromise patient safety and test reliability.
	Malfunction may occur if this part becomes dusty or dirty.
	The reliability of each chart can be different depending on user’s ability and experience. Prior to use, the operator must be sufficiently familiar with each chart type.

	Use only the power supply adapter and power cord specified by the manufacturer. Use of other adapters may cause malfunction or damage.
	Do not install the product using a wall mount bracket not specified by the manufacturer. Improper installation may cause the device to fall, resulting in product damage or personal injury.
	<ul style="list-style-type: none"> - Install the device on a wall that is sturdy enough to support the weight (5kg). - Use the wall mount bracket verified and supplied by manufacturer. - Request for specialist's help as needed. - Contact manufacturer or authorized local distributor when any problem occurs during installation
	<ul style="list-style-type: none"> - Never operate the device while installation. - Do not touch the device with wet hands in order to avoid electric shock.
	Use the wall mount bracket verified and supplied by manufacturer.
	<ul style="list-style-type: none"> - Never install the wall mount bracket on a flimsy wall. - Do not drill holes larger than necessary.
	<ul style="list-style-type: none"> - The device shall be held by two persons. - After hanging the instrument into the wall mount bracket, check the safety of connection.
	All electric wires shall be connected firmly.
	<ul style="list-style-type: none"> - Never plug the power cord in a socket outlet which does not have any PROTECTIVE EARTH Terminal. - Do not touch any electrical components with wet hands in order to avoid electric shock.
	Be cautious about the polarity of battery.
	Never use other electric source except applicable battery.
	Do not disconnect power source in the progress of booting.
	If test distance set improperly, the result may be inaccurate.

	- Incorrect configuration of display unit may result in erroneous test result.
	Change the channel of MENU function in main body prior to change one of remote-control.
	An invalid remote-control channel setting may affect other visual acuity chart systems located in the same room.
	- Incorrect configuration of mirror function may result in erroneous test result.
	For more accurate test, adjust the red color value corresponding with the condition of Red/Green glasses.
	For more accurate test, adjust green color value corresponding with the condition of Red/Green glasses.
	For more accurate test, adjust brightness value in harmony with the surrounding environment.
	If a baud-rate sets improperly, serial communication cannot work well. Consult with specialist for this part.
	Some images may not display if their format is not supported.
	Some of videos cannot be played due to not-supported video format.
	For detailed function of slide, consult with manufacturer or authorized local distributor.
	Turn the power off and unplug the power cord from a socket outlet before cleaning.
	Wiping with tissue paper by damage the screen seriously.
	In case of cleaning, excessive force or loading may result in failure.
	Do not leave water drops on the device. If the device is splashed with water, immediately wipe with absorbent cotton or a soft cloth.
	Never use an organic solvent such as paint thinner.

	<p>Do not store or use in place with the following conditions:</p> <ul style="list-style-type: none">- harmful gases or polluted air;- blowing dust or sand;- easy exposure to oil residue or fuel elements;- atmosphere that has above standard levels of salt;- prone to dust collecting;- floor surface with a slope higher than 10°;- voltage from wall sockets is changing severely;- exposure to direct sunlight.
	<p>No modification of this equipment is allowed.</p>
	<p>Do not modify this equipment without authorization of the manufacture.</p>
	<p>If this equipment is modified, appropriate inspection and testing must be conducted to ensure continued safe use of the equipment.</p>

3.1 Reporting of Serious Incidents

Any serious incident that has occurred in relation to the device shall be reported to the manufacturer and to the competent authority of the Member State in which the user and/or patient is located.

4 Device description

4.1 Main body

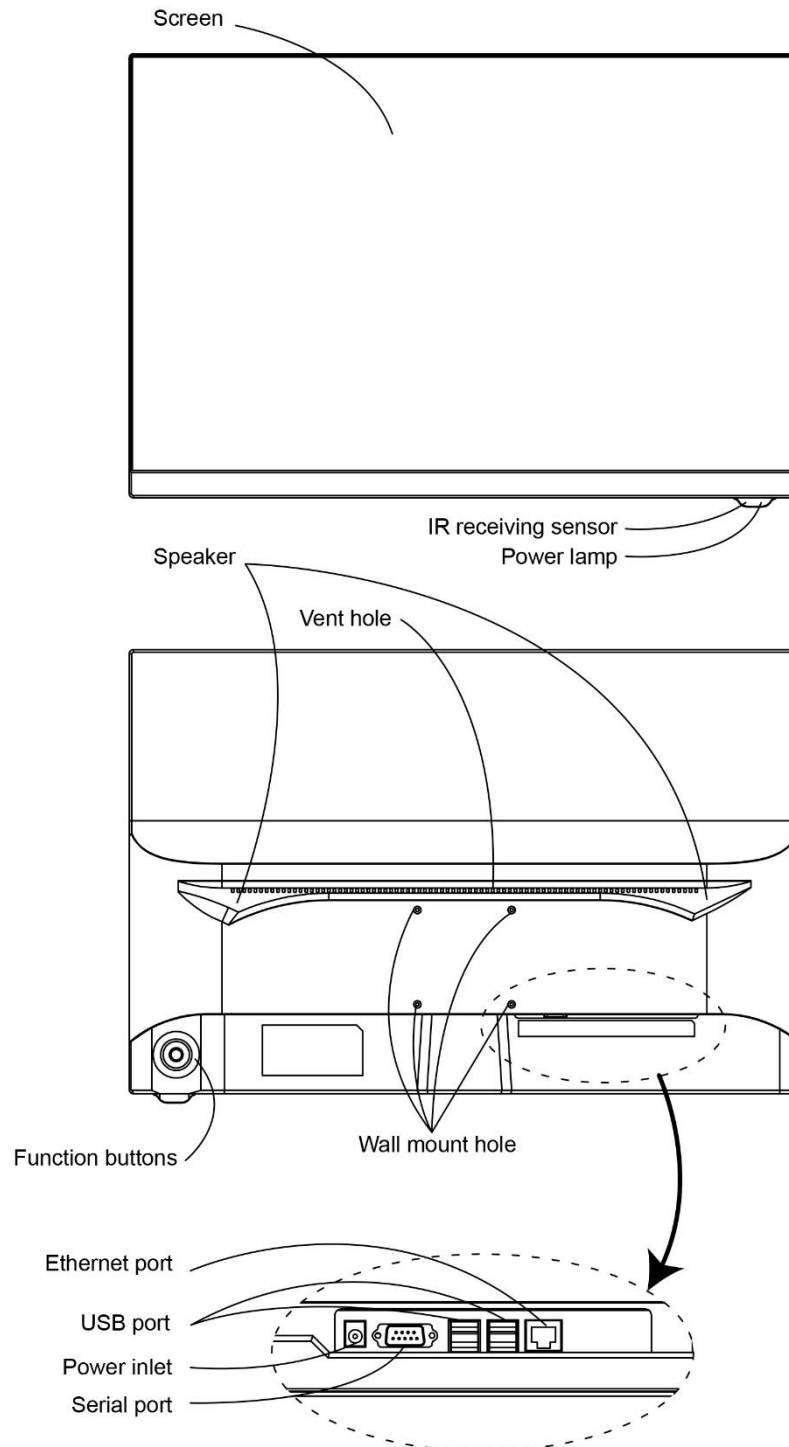

Description	Function
Screen	Displaying the charts or functional information
IR receiving sensor	Receiving IR signal from the remote-control
Power lamp	Showing power on or off
Wall mount hole	Connecting parts to be mounted for wall mount bracket
Vent hole	Discharging heat of internal parts
Ethernet port	Connecting for using communication with RJ45
USB port	Connecting with USB device
Power inlet	Connecting with power source
Speaker	Making a sound functional alarm
Function buttons	Executing internal functions such as power switch

4.2 Remote-control



[IR signal sender]

This part is for sending infrared signal to main body.



Malfunction may occur if this part becomes dusty or dirty.

[Power on/off]

It turns on or off.

[Screen on/off]





Without power supplying, it switches screen on or off only.

[Function button]

Performs various customized functions requested by local distributors. Please contact your local distributor for more information.

[Fast selection of chart]

It enables to select one of 5 types in VA charts stored basically in the flash-memory directly.

Buttons	Functions
K	Alphabet
2	Numbers
E	Tumbling E
C	Landolt ring
	<p>Pediatric charts consist of 3 kinds. When it is pressed, it changes sequentially.</p> <div style="display: flex; justify-content: space-around; align-items: center;"> <div style="text-align: center;">  <p>Traditional chart</p> </div> <div style="text-align: center;">  <p>Allen Figure</p> </div> <div style="text-align: center;">  <p>L-E-A Figure</p> </div> </div>

[Adjusting size of chart]

It can adjust the size of chart from VA 0.03 to VA 2.0 for each type of VA chart. [Decimal option]











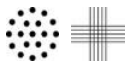



[INDEX] display unit ¹⁾				
Meter	Feet	Feet ²⁾	Decimal	LogMAR
6/200	20/660	20/660	0.03	1.52
6/120	20/400	20/400	0.05	1.30
6/85	20/300	20/300	0.07	1.15
6/60	20/200	20/200	0.1	1.00
6/48	20/150	20/150	0.15	0.80
6/40	20/100	20/100	0.2	0.70
6/36	20/90	20/80	0.3	0.52
6/30	20/80	20/70	0.4	0.40
6/24	20/70	20/60	0.5	0.30
6/21	20/60	20/50	0.6	0.22
6/18	20/50	20/40	0.7	0.15
6/15	20/40	20/30	0.8	0.10
6/12	20/30	20/25	0.9	0.05
6/9	20/20	20/20	1.0	0.00
6/7.5	20/20	20/20	1.2	-0.08
6/6	20/15	20/15	1.5	-0.18
6/4.5	20/10	20/10	2.0	-0.30









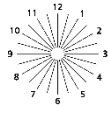

¹⁾ Display unit [INDEX] can be changed in MENU screen.



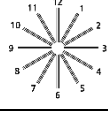
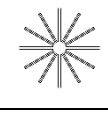
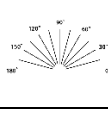
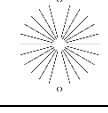
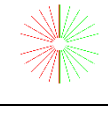

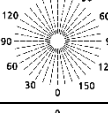

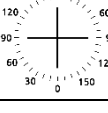



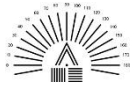



²⁾ You can choose a different kind of FEET display unit by making a request in advance.

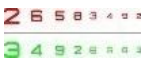

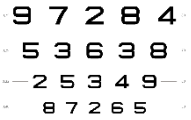

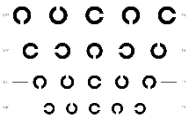











[Selection of special chart]















It shows a lot of special charts on the screen.





Buttons	Displays	Functions
		Astigmatic chart for using cross-cylinder #1
		Astigmatic chart for using cross-cylinder #2
		The chart for measuring astigmatic axis
		Amsler grid for diagnosis of retianl disease #1
		Amsler grid for diagnosis of retianl disease #2
		Amsler grid for diagnosis of retianl disease #3
		Metamorphopsia chart #1
		Metamorphopsia chart #2
		Metamorphopsia chart #3
		The chart for measuring astigmatic axis (Clock dial) #1
		The chart for measuring astigmatic axis (Clock dial) #2
		The chart for measuring astigmatic axis (Clock dial) #3
		The chart for measuring astigmatic axis (Clock dial) #4

Buttons	Displays	Functions
		The chart for measuring astigmatic axis (Clock dial) #5
		The chart for measuring astigmatic axis (Clock dial) #6
		The chart for measuring astigmatic axis (Clock dial) #7
		The chart for measuring astigmatic axis (Clock dial) #8
		The chart for measuring astigmatic axis (Clock dial) #9
		The chart for measuring astigmatic axis (Clock dial) #10
		The chart for measuring astigmatic axis (Clock dial) #11
		The chart for measuring astigmatic axis (Clock dial) #12
		The chart for measuring astigmatic axis (Clock dial) #13
		The chart for measuring astigmatic axis (Clock dial) #14
		The chart for measuring astigmatic axis (Clock dial) #15
		The chart for measuring astigmatic axis (Clock dial) #16
		The chart for measuring astigmatic axis (Clock dial) #17
		Rotating circle lines for measuring precise astigmatic axis

Buttons	Displays	Functions
		Fan & Block chart for measuring convenient astigmatic axis
		Color anomaly charts
		Color anomaly charts for three colors
	Duochrome test chart #1	
	Duochrome test chart #2	
	Binocular balance test chart	
ETDRS		ETDRS: Early Treatment Diabetic Retinopathy Study (Alphabet)
		ETDRS: Early Treatment Diabetic Retinopathy Study (Numbers)
		ETDRS: Early Treatment Diabetic Retinopathy Study (Tumbling E)
		ETDRS: Early Treatment Diabetic Retinopathy Study (Landolt Ring)
		ETDRS: Early Treatment Diabetic Retinopathy Study (Pediatric)
		Cross phoria test with fixation

Buttons	Displays	Functions
		Cross phoria test
		Vertical coincidence with fixation
		Vertical coincidence
		Horizontal coincidence with fixation
		Horizontal coincidence
		Dot chart
		Fixation chart #1
		Fixation chart #2
		Fixation chart #3
		Fixation chart #4
		Stereo test for distance #1
		Stereo test for distance #2
		Stereo test for distance #3
		Stereo test for distance #4

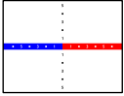
Buttons	Displays	Functions
		Stereo test for distance #5
		Cyclophoria #1
		Cyclophoria #2
		Cyclophoria #3
		Fixation disparity test #1
		Fixation disparity test #2
		Fixation disparity test #3
		Fixation disparity test #4
		Stereo test for distance #6
		Stereo test for distance #7
		Stereo test for distance #8
		Stereo test for distance #9
		Stereo test for distance #10

Buttons	Displays	Functions
		Worth 4 dots
		Torrington chart
	Schober Test (Cross-mark moveable)	



The reliability of each chart can be different depending on user's ability and experience. Prior to use, the operator must be sufficiently familiar with each chart type.

[Crowding mask]

Crowding bars put surrounding specific VA chart.

[Red/Green mask]

Red/Green color background put behind VA charts.

[Image slide function]

It shows various images and video such as anatomy chart and advertisement to patients.

[Screen reverse function]

It reverses the color between black and white for special measurement.



[Random chart]

It displays random chart in the same VA charts.



[Program function]

It memorizes the chart and order before use. And, it displays memorized chart.



[Direction movement]

Where it needs, it carries out movement of direction for insertion of masks, change of setup, change of special chart and so on.

[Adjusting the contrast of chart]

It increases or decreases the contrast of chart.

[Mask selection]

	It displays vertical one line of the chart.
	It displays horizontal one line of the chart.
	It displays one character of the chart.

[MENU function]

It enters in MENU screen to preset all environmental variables such as test distance, brightness and so on.

[SET function]

In program function or MENU function, it stores current set values or variables.

4.3 Accessories

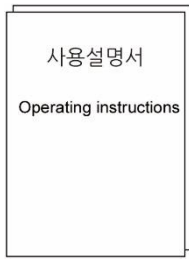

Operating instructions

UM-101

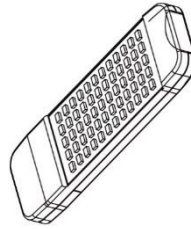

Remote-control

R1-A01

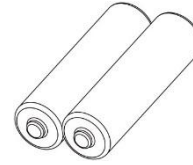

Two pieces of batteries

(IEC R6)

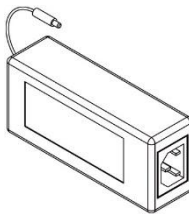

Power supply

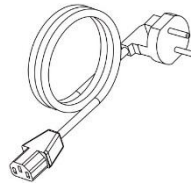

Power cord

KKP/30/KKS-16A

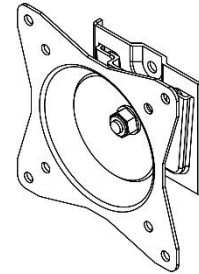



Wall mount bracket

Y-620

<p>NOTE</p>	<p>The Operating instructions are provided in English or Korean as standard. For other languages, please contact your local distributor upon request.</p>
<p>NOTE</p>	<p>According to International Civil Aviation Organization – ICAO and IATA Dangerous Good Regulations – DGR, the transport of batteries may be restricted or prohibited on certain airlines or in specific countries. Therefore, some accessories of this product may be shipped without batteries included.</p>
	<p>Use only the power supply adapter and power cord specified by the manufacturer. Use of other adapters may cause malfunction or damage.</p>
	<p>Do not install the product using a wall mount bracket not specified by the manufacturer. Improper installation may cause the device to fall, resulting in product damage or personal injury.</p>



5 Installation

	<ul style="list-style-type: none"> - Install the device on a wall that is sturdy enough to support the weight (5kg). - Use the wall mount bracket verified and supplied by manufacturer. - Request for specialist's help as needed. - Contact manufacturer or authorized local distributor when any problem occurs during installation
	<ul style="list-style-type: none"> - Never operate the device while installation. - Do not touch the device with wet hands in order to avoid electric shock.

5.1 Installation of wall mount bracket

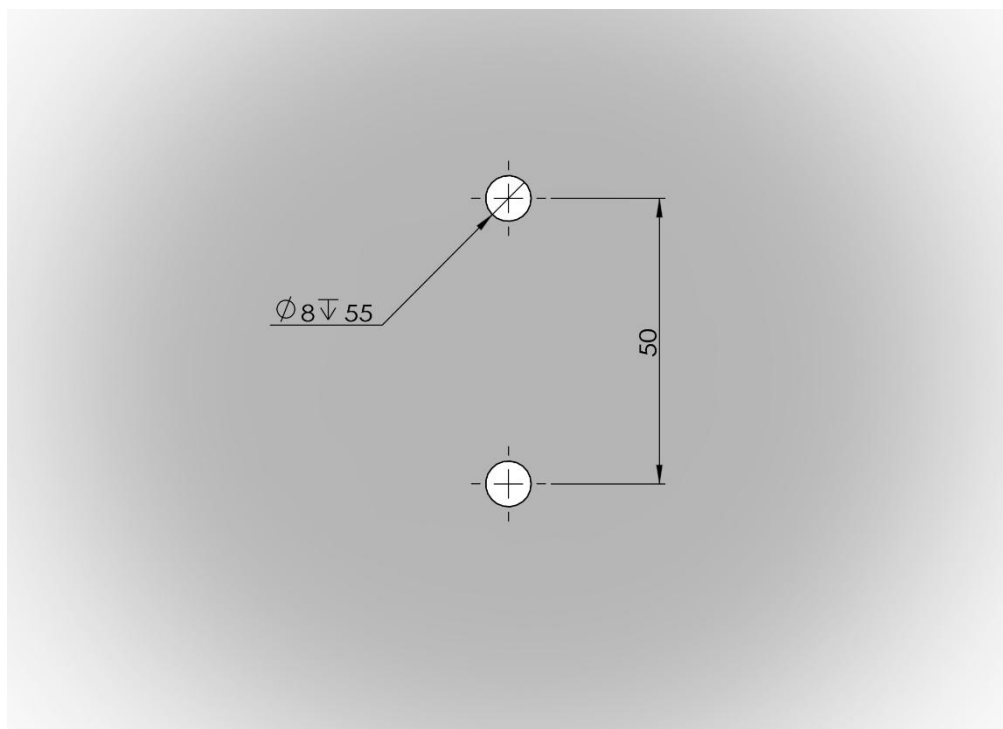
(1) With an electric power drill, drill two holes - 8mm diameter in sturdy and safe wall as follow.



	<p>Use the wall mount bracket verified and supplied by manufacturer.</p>
	<ul style="list-style-type: none"> - Never install the wall mount bracket on a flimsy wall. - Do not drill holes larger than necessary.

(2) If the material of wall to be attached is stone, put the plastic anchors into the drilling holes.

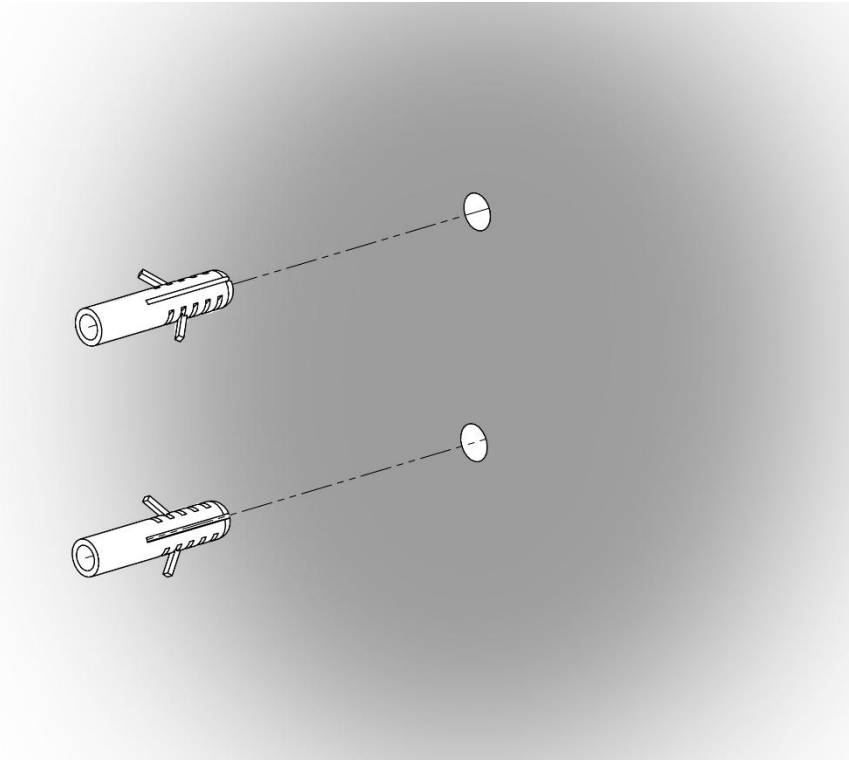

- (3) Place the female wall-mount bracket in alignment with the drilled holes, and then tighten round tapping bolts (M5 x 55L). As needed, put anchor blocks (M5) prior to tightening four round tapping bolts (M5 x 55L).

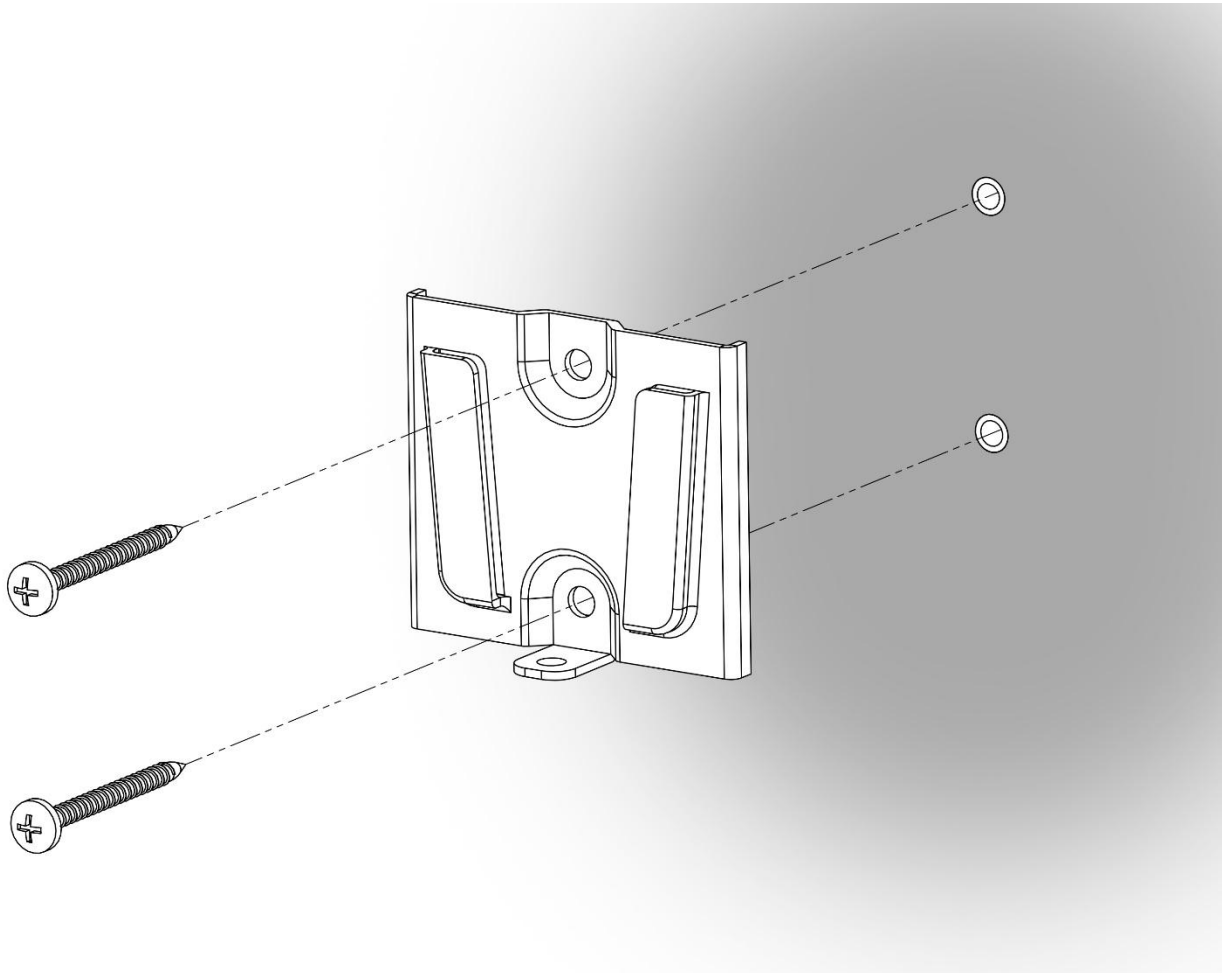

- (4) Place wall mount bracket (Male) on the place corresponding with wall mount holes, and then tighten four screw bolts (M4 x 5L).

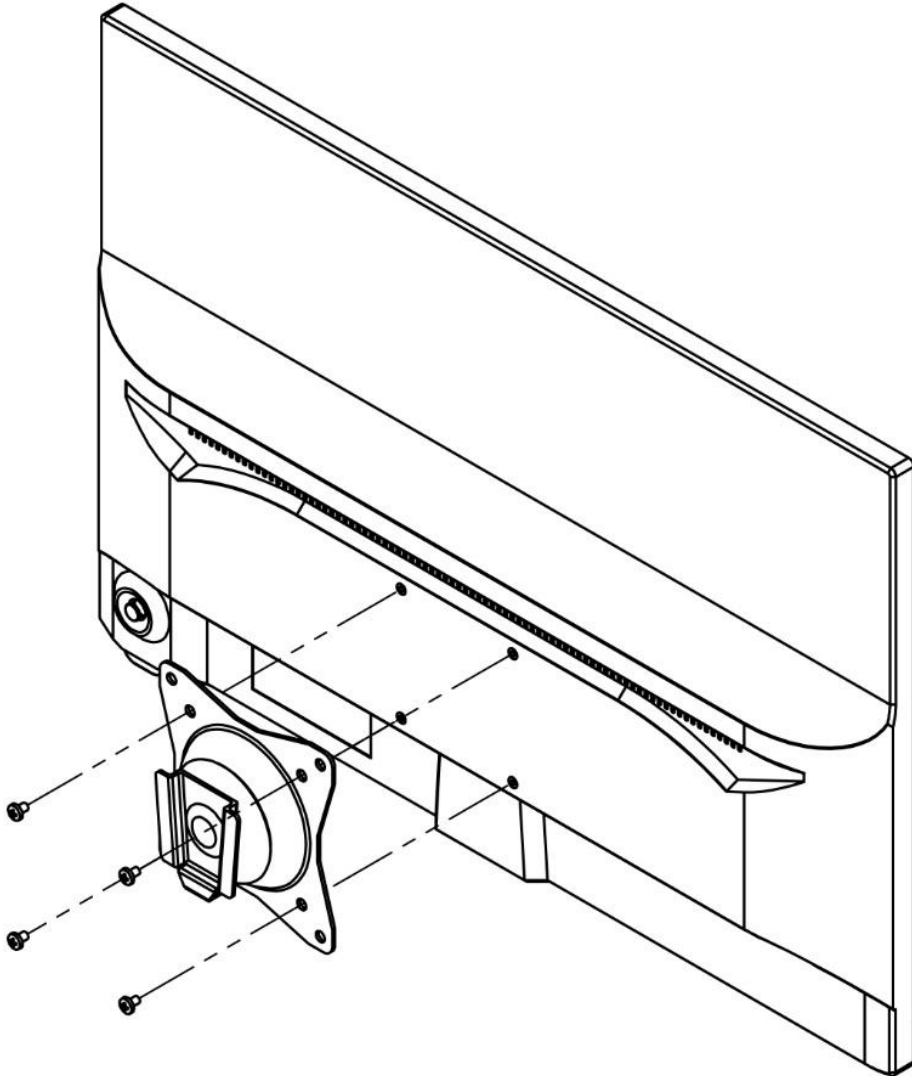

(5) CAREFULLY, hang the wall mount bracket (Male) into the wall mount bracket (Female) located on the wall.

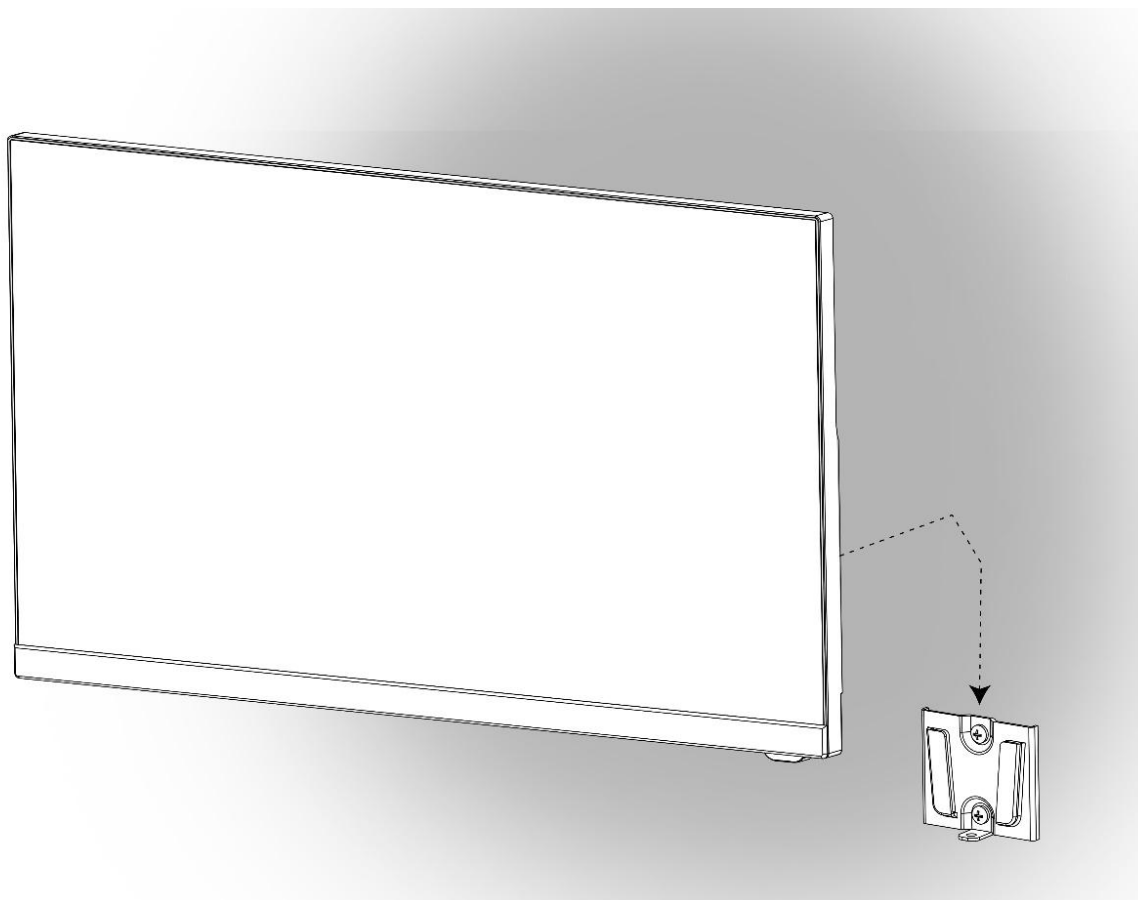

- The device shall be held by two persons.
- After hanging the instrument into the wall mount bracket, check the safety of connection.

5.2 Wiring

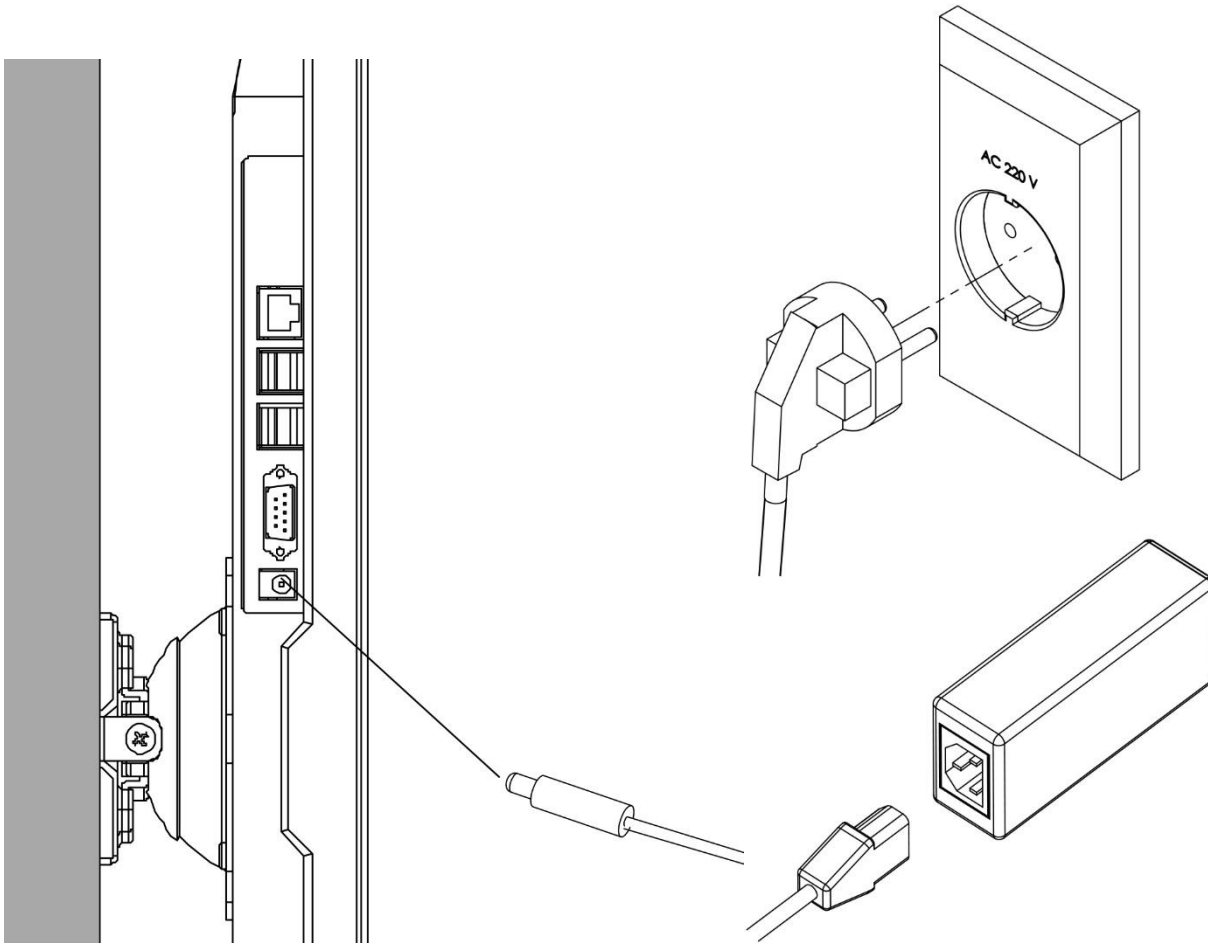

- (1) Plug the output connector of power supply in a power inlet of main body.
- (2) Plug the power cord in a socket outlet located on the wall, and then insert opposite part of power cord in a socket located on power supply.



All electric wires shall be connected firmly.



- Never plug the power cord in a socket outlet which does not have any PROTECTIVE EARTH Terminal.
- Do not touch any electrical components with wet hands in order to avoid electric shock.

5.3 Preparation of remote-control

- (1) Open a battery cover of remote-control.
- (2) Put two batteries with the correct polarity in to battery holes.
- (3) Close a battery cover firmly.

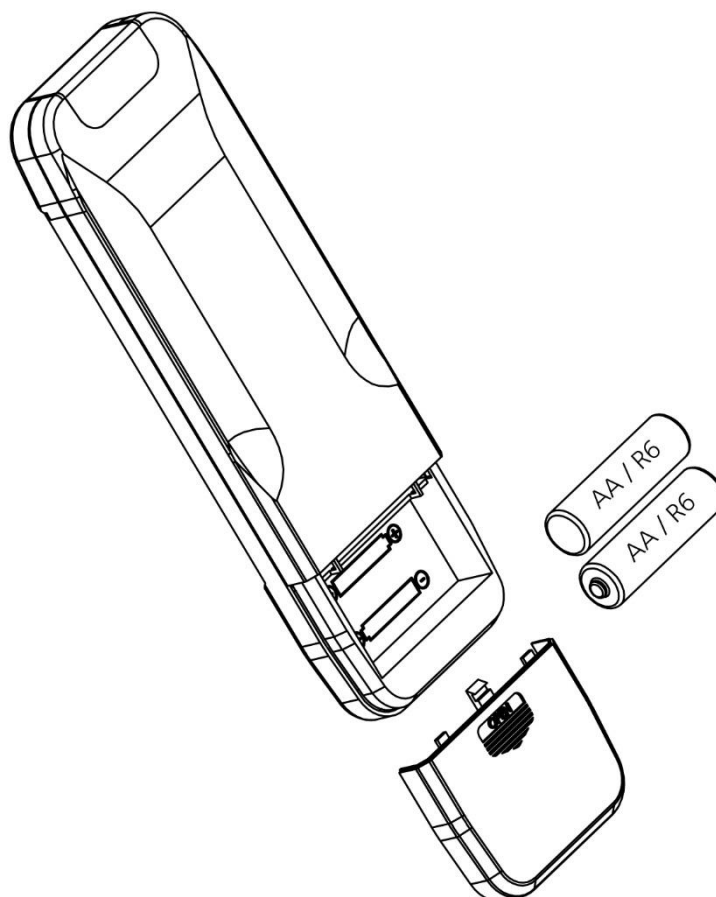

Applicable battery type

International Standard	R6 or LR6
U.S. and Korea	AA
Japan	UM3 or AM3

















Be cautious about polarity of the battery.

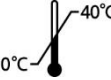

Never use other electric source except applicable battery.

6 Label and symbols

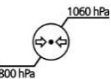
To call attention to operators, some labels and indications are provided on the device. If labels are curling up or characters are fading and becoming barely legible, contact manufacturer or authorized local distributor.

Symbols	Description	Reference
	Operating instructions	ISO 7000:2019-1641
	Caution	ISO 7000:2019-0434A
	General prohibition sign and template for constructing a prohibition sign	ISO 7010:2019-P001
	Direct current	IEC 60417:2025-5031
	Alternating current	IEC 60417:2025-5032
	Refer to instruction manual/ booklet	ISO 7010:2019-M002
	Date of manufacture	ISO 7000:2019-2497
	Manufacturer	ISO 7000:2019-3082
	Serial number	ISO 7000:2019-2498
	Keep away from rain	ISO 7000:2019-0626
	Use no hook	ISO 7000:2019-0622
	Temperature limit	ISO 7000:2019-0632
	Humidity limitation	ISO 7000:2019-2620
	Atmospheric pressure limitation	ISO 7000:2019-2621
	Waste electrical and electronic equipment	Directive 2012/19/EU ANNEX IX

6.1 Main body

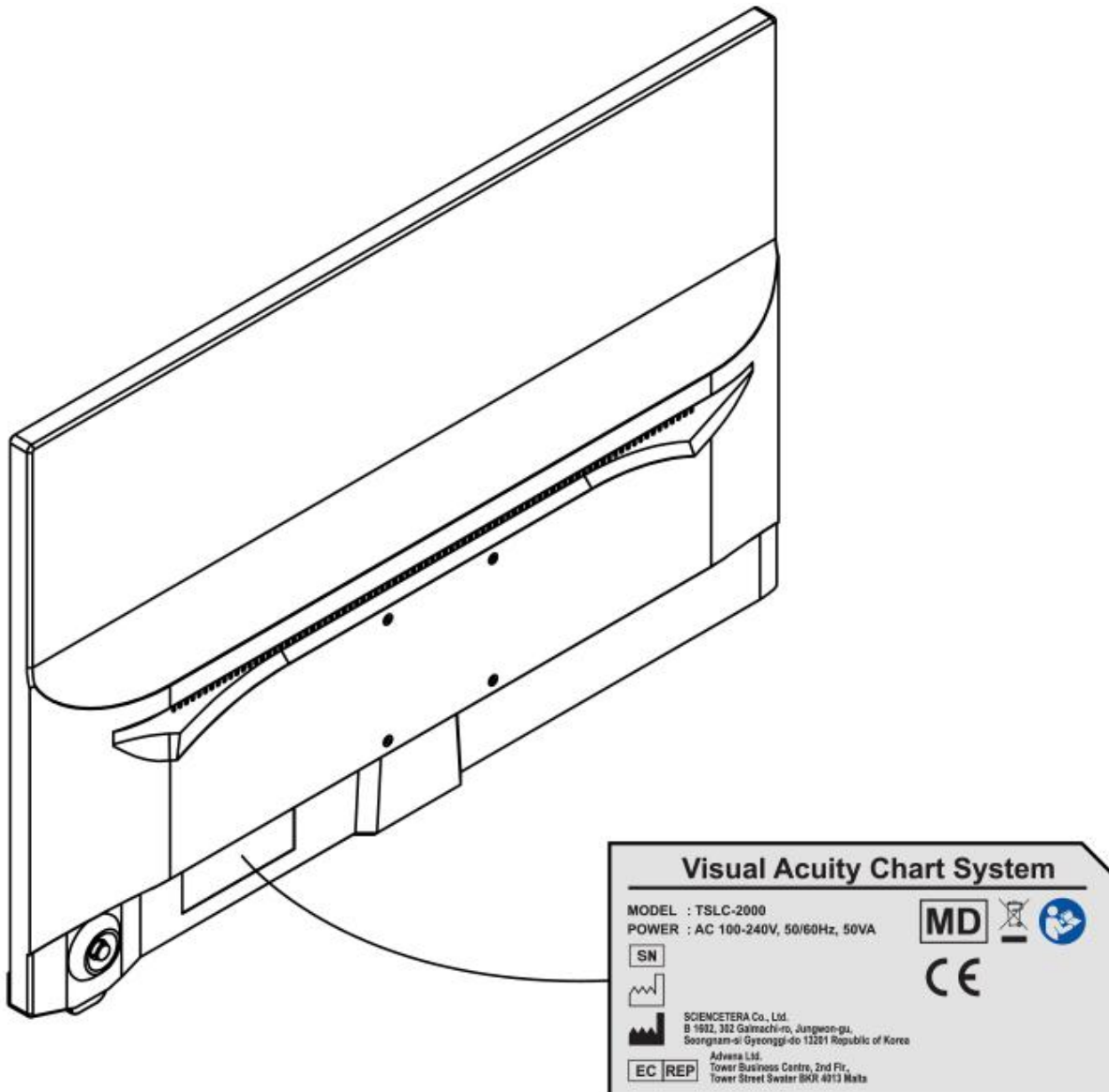

6.2 Remote-control



7 Preparation

7.1 Booting

(1) When you plug power cord in socket outlet, the booting is carried out with showing following image on the screen.



(2) After few seconds, visual acuity chart system displays on the screen as follow.

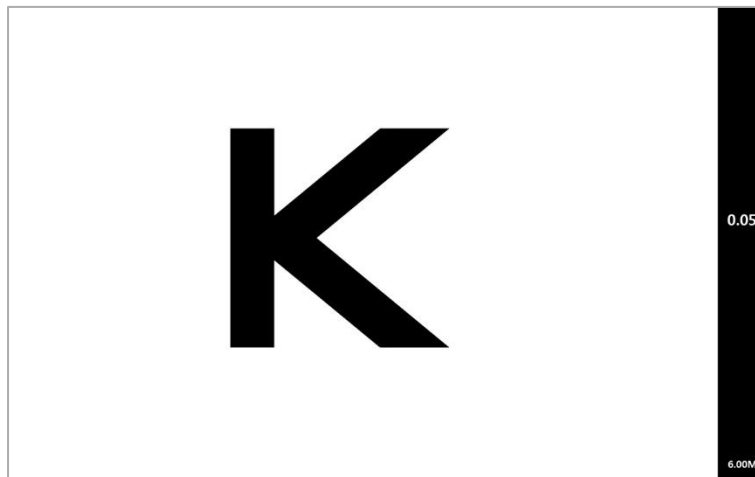

Do not disconnect power source in the progress of booting.

7.2 Preset function in MENU screen

(1) In order to enter the preset function, press MENU button on remote-control.

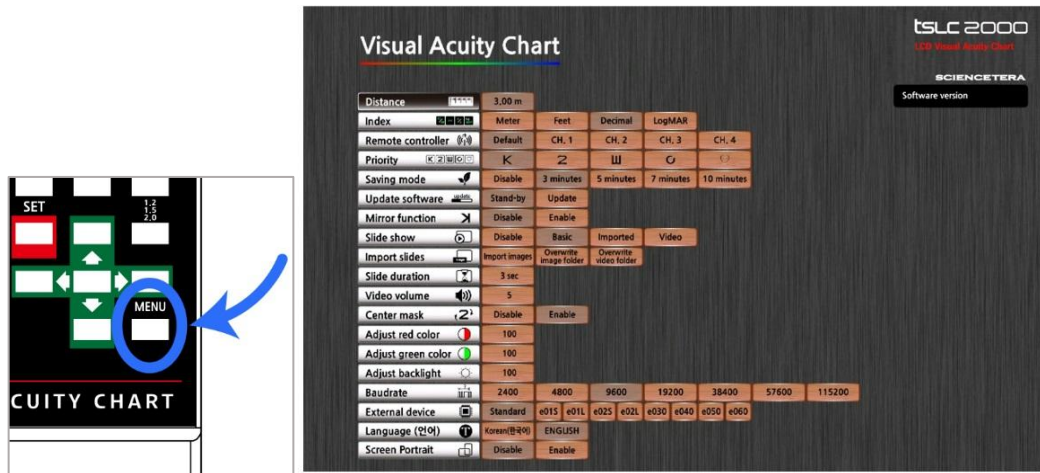

How to navigate in MENU function.



(2) **[Distance]** Select test distance correctly according to the environment of refraction room. It is adjustable from 1.5 to 8 meter. ((4.75 to 26 ft)



If test distance set improperly, the result may be inaccurate.

(3) **[Index]** Select the display unit of Visual Acuity.

[INDEX] display unit				
Meter	Feet	Feet ¹⁾	Decimal	LogMAR
6/200	20/660	20/660	0.03	1.52
6/120	20/400	20/400	0.05	1.30
6/85	20/300	20/300	0.07	1.15
6/60	20/200	20/200	0.1	1.00
6/48	20/150	20/150	0.15	0.80
6/40	20/100	20/100	0.2	0.70
6/36	20/90	20/80	0.3	0.52
6/30	20/80	20/70	0.4	0.40
6/24	20/70	20/60	0.5	0.30
6/21	20/60	20/50	0.6	0.22
6/18	20/50	20/40	0.7	0.15
6/15	20/40	20/30	0.8	0.10
6/12	20/30	20/25	0.9	0.05
6/9	20/20	20/20	1.0	0.00
6/7.5	20/20	20/20	1.2	-0.08
6/6	20/15	20/15	1.5	-0.18
6/4.5	20/10	20/10	2.0	-0.30

¹⁾ You can choose a different kind of FEET display unit by making a request in advance.



Incorrect configuration of display unit may result in erroneous test result.

(4) **[Remote-control]** Select applicable the channel of remote-control.

This product can be used maximum four devices in the adjacent places without interference of remote-control's signals. If more than two devices are used in the room, it shall be selected.



How to set the channel of remote-control.

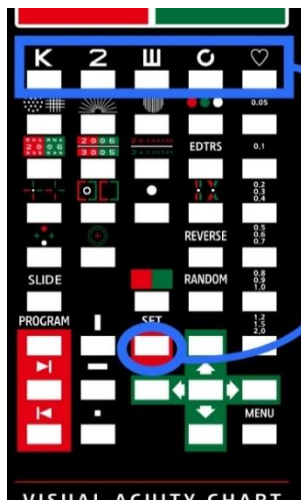

While pressing SET button, press one of **K Z W G** ♡ for three(3) second.

- K** : default
- Z** : no.1
- W** : no.2
- G** : no.3
- ♡ : no.4

	Change the channel of MENU function in main body prior to change one of remote-control.
	An invalid remote-control channel setting may affect other visual acuity chart systems located in the same room.

(5) **[Priority]** Select a type of visual acuity chart to be shown firstly on the screen when the power on.

Alphabet	Number	Tumbling E	Landolt ring	Pediatric
K	2	Ш	⊖	

(6) **[Saving mode]** Select the duration for entering power saving function.

(7) **[Update software]** Enable to update internal software easily. For more information, consult with manufacturer or authorized local distributor.

(8) **[Mirror function]** When used at a short distance less than 1.5 meters, the chart to be reflected on the mirror can be displayed on the screen.

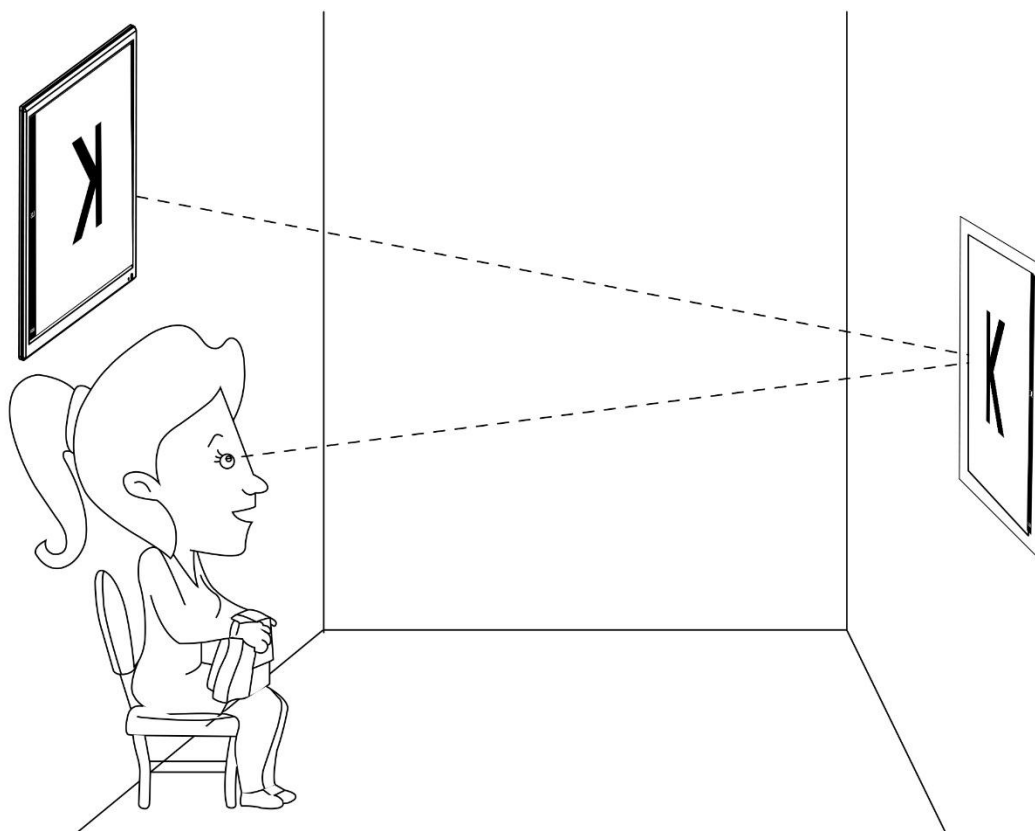

Incorrect configuration of mirror function may result in erroneous test result.

(9) **[Slide show]** Select the images or videos to be shown on the screen in case of executing image slide function.

Disable	Nothing to show
Basic	Display basic images stored in internal flash memory by manufacturer.
Imported	Display images stored in internal flash memory by operator.
Video	Display video stored in internal flash memory by operator.

(10) **[Import slides]** Enables to import new image and video files from external USB Drive or to over-write all image or video files in the internal flash memory.

(11) **[Slide duration]** Select a duration of slide function. It means that the delay time between image slides.

(12) **[Video volume]** Adjust sound volume from 0 to 15 points.

(13) **[Center mask]** Select the position to display visual acuity chart on the screen in case of activating mask function.

Disable	
Enable	

(14) **[Adjust red color]** Adjust the brightness of red color for all charts.

	For more accurate test, adjust brightness value of red color corresponding with the condition of Red/Green glasses.
--	---------------------------------------------------------------------------------------------------------------------

(15) **[Adjust green color]** Adjust the brightness of green color for all charts.

	For more accurate test, adjust brightness value of green color corresponding with the condition of Red/Green glasses.
--	-----------------------------------------------------------------------------------------------------------------------

(16) **[Adjust backlight]** Adjust the brightness of backlight on the screen.

	For more accurate test, adjust brightness value in harmony with the surrounding environment.
--	----------------------------------------------------------------------------------------------

(17) **[Baudrate]** Select a baud-rate for serial communication with external device such as digital refractor, desktop and so on. For this, consult with manufacturer or authorized local distributor.



If a baud-rate sets improperly, serial communication cannot work well. Consult with specialist for this part.

(18) **[External device]** Select a device type using serial communication to connect with external device. For this, consult with manufacturer or authorized local distributor.

(19) **[Screen Portrait]** All information to be displayed on the screen is rotated through 90 degrees in order to use this instrument vertically.

Disable	Enable

(20) After presetting all parameters, press SET button on remote-control. And then, press MENU button.

8 Operation

8.1 General visual acuity test

(1) Select the type of chart you want to use and press the corresponding button.

K	2	Ш	⦿	♥
Alphabet	Number	Tumbling E	Landolt ring	Children

(2) Press “Adjusting the size of chart” button to change desired size.

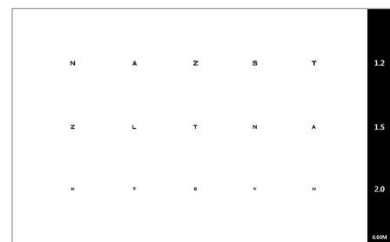
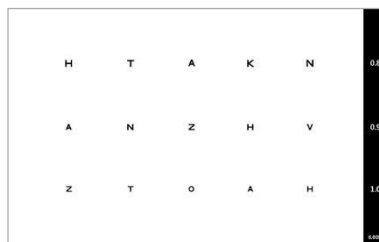
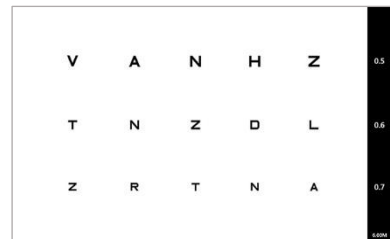
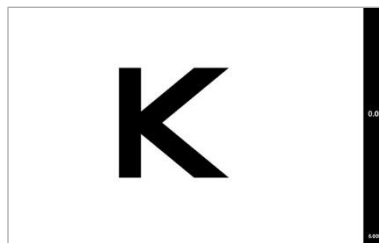
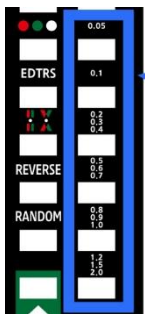

(3) As needed, mask function enables to do comfortable testing visually for patient.

Press one of "Mask selection" buttons on the remote-control.

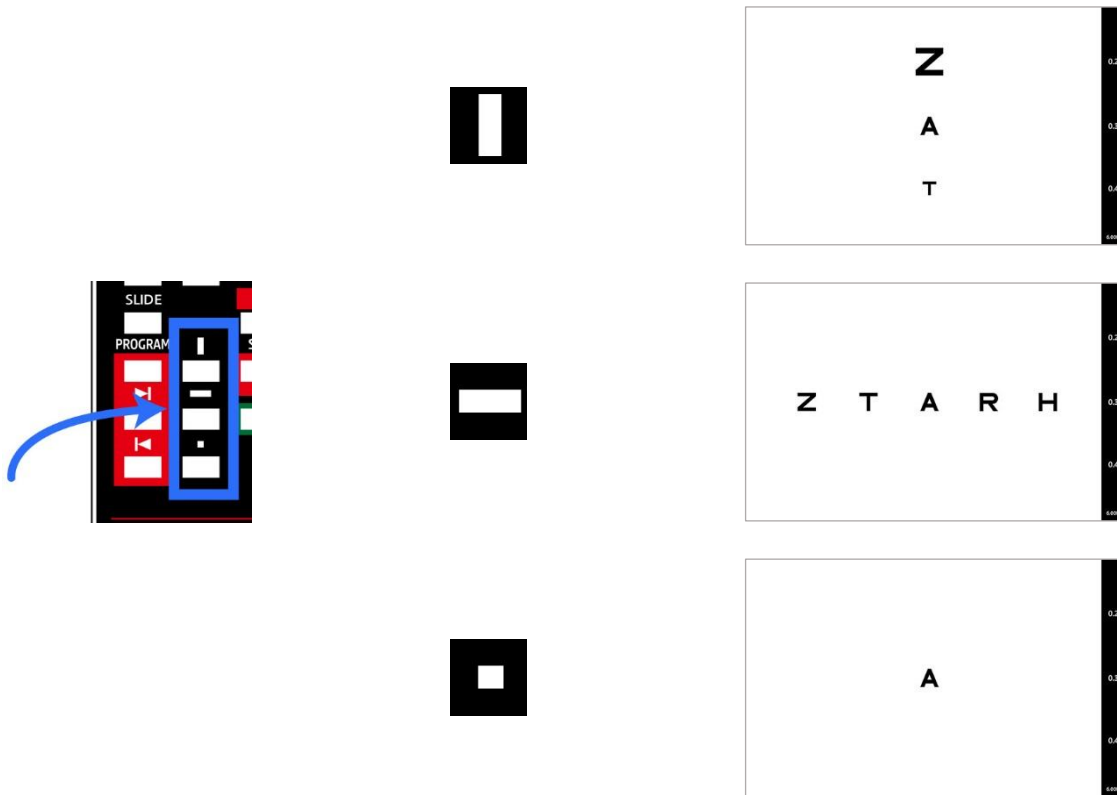

The diagram illustrates three mask selection options on a remote control and their corresponding visual acuity chart displays. The remote control has a 'PROGRAM' section with several buttons; a blue box highlights the mask selection buttons, and a blue arrow points to the first one.

- Mask 1:** A vertical rectangular mask. The corresponding chart shows the letters 'Z', 'A', and 'T' arranged vertically. The chart includes a vertical scale on the right with markings for 0.2, 0.3, 0.4, and 5.000.
- Mask 2:** A horizontal rectangular mask. The corresponding chart shows the letters 'Z', 'T', 'A', 'R', and 'H' arranged horizontally. The chart includes a vertical scale on the right with markings for 0.2, 0.3, 0.4, and 5.000.
- Mask 3:** A square mask. The corresponding chart shows the letter 'A' centered. The chart includes a vertical scale on the right with markings for 0.2, 0.3, 0.4, and 5.000.

How to use mask function

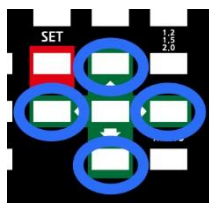

◀ or ▶

Move left or right

▲ or ▼

Move up or down

(3) As needed, red/green mask function can put behind Visual Acuity chart as background.

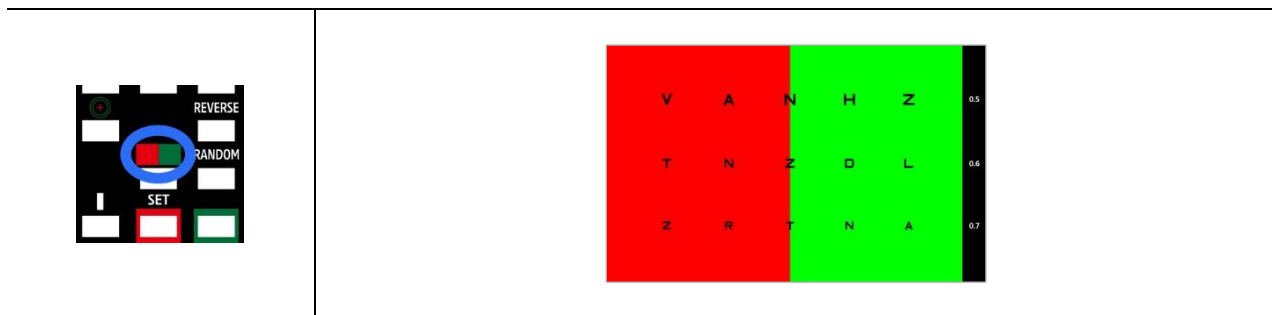

(4) As needed, random chart can be displayed on the screen by pressing “Random chart” button.

What is RANDOM Chart?

Randomly rearranges letter order at the same VA. This prevents erroneous test result from the patient memorizing the charts.

By pressing “Screen reverse function” button on the remote-control, the color between charts and background is changed. Make the best use of this function according to refraction environment.

Tips!

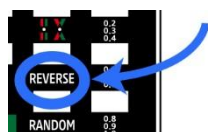

8.2 Astigmatism test

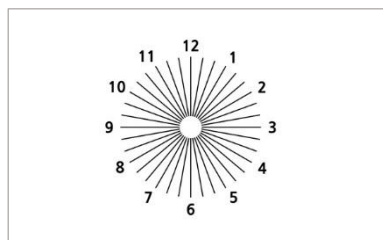
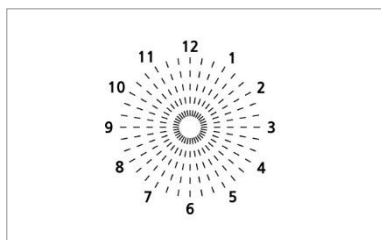
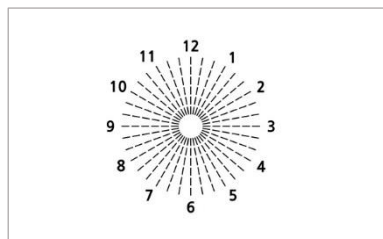
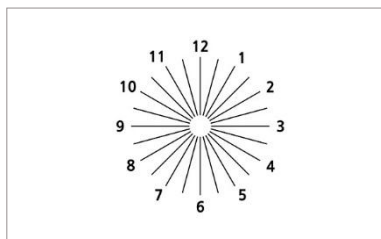
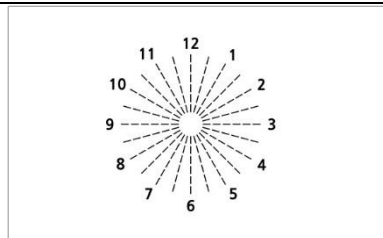
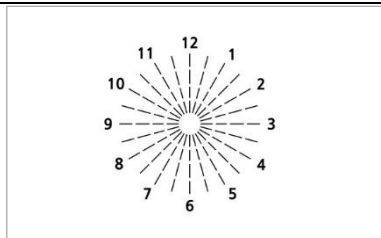
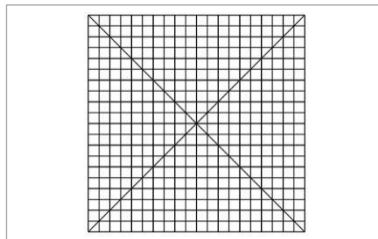
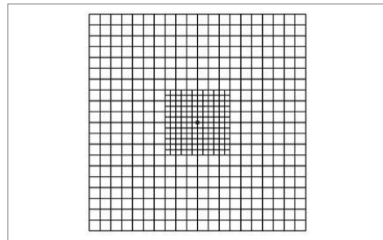
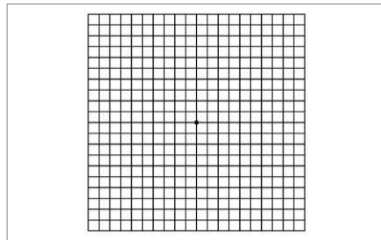
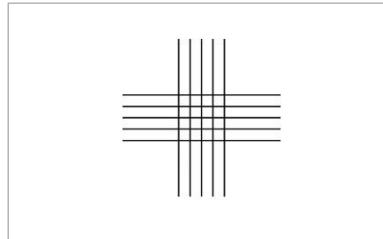
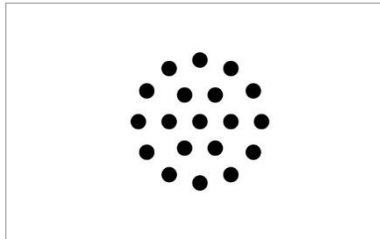

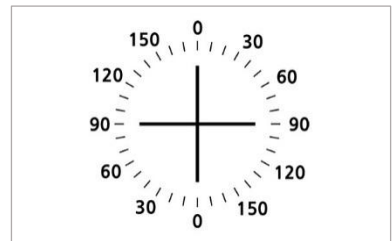
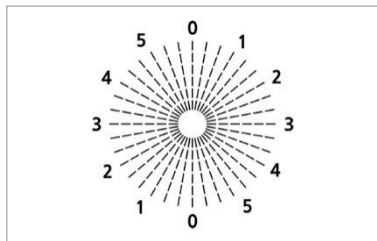
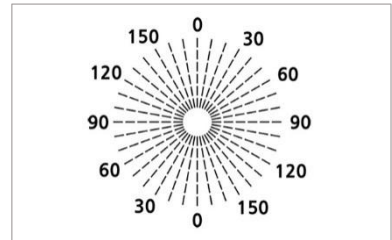
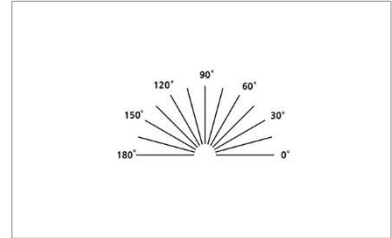
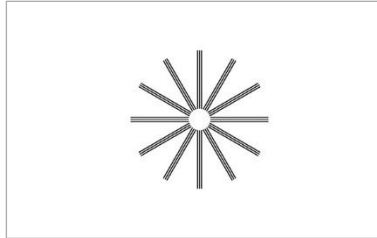
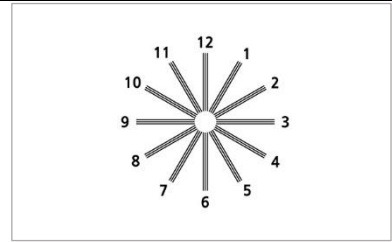
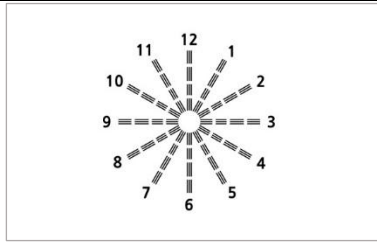

The chart can be rotated 10 degree by pressing ◀ or ▶ button.

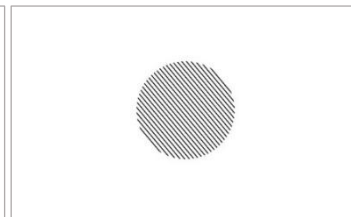
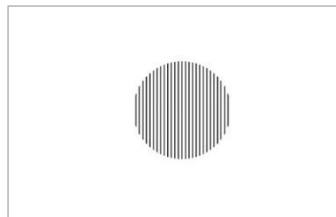

The chart can be rotated 10 degree by pressing ◀ or ▶ button.

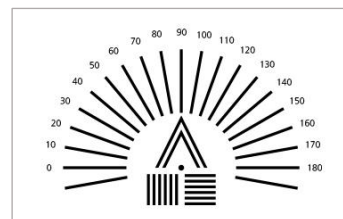



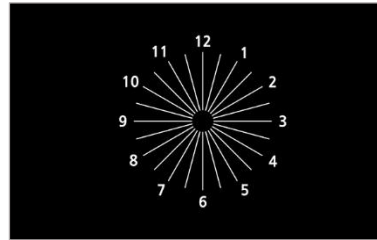
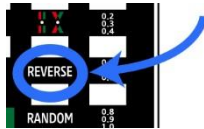

Tips!

By pressing “Screen reverse function” button on the remote-control, the color between charts and background is changed. Make the best use of this function according to refraction environment.

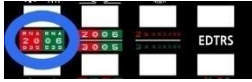

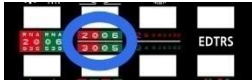
8.3 Duo-chrome

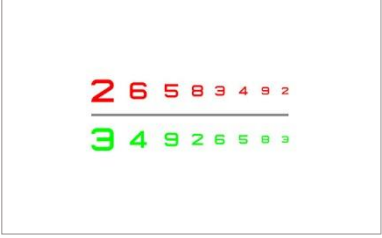



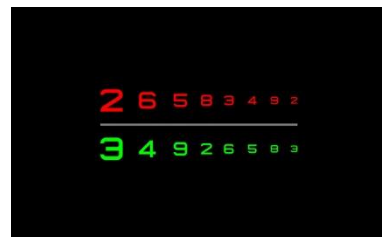
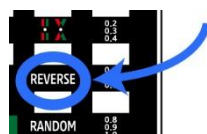

Tips!

By pressing “Screen reverse function” button on the remote-control, the color between charts and background is changed. Make the best use of this function according to refraction environment.

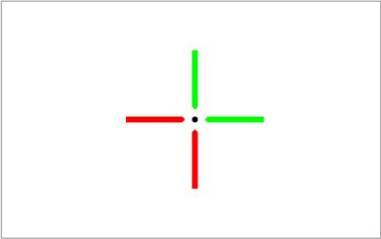
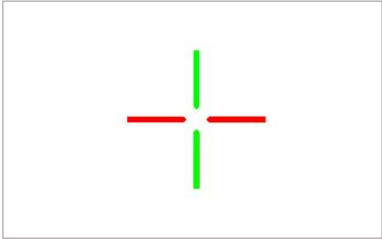

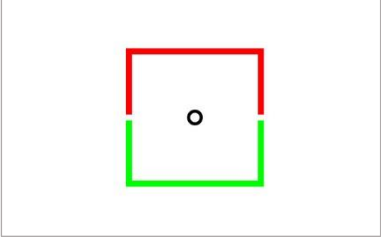
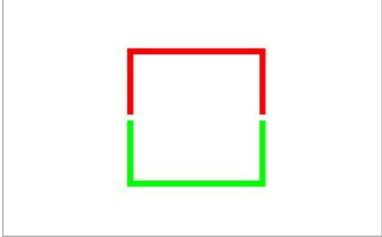
8.4 Phoria test

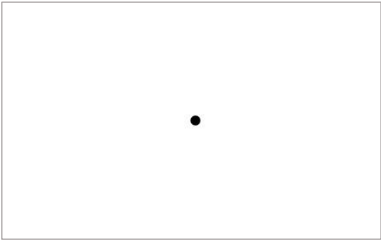
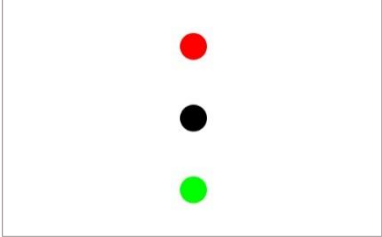
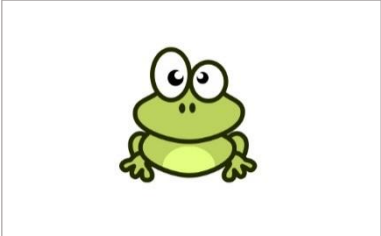
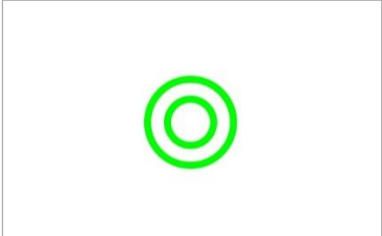
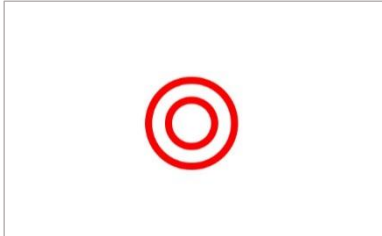

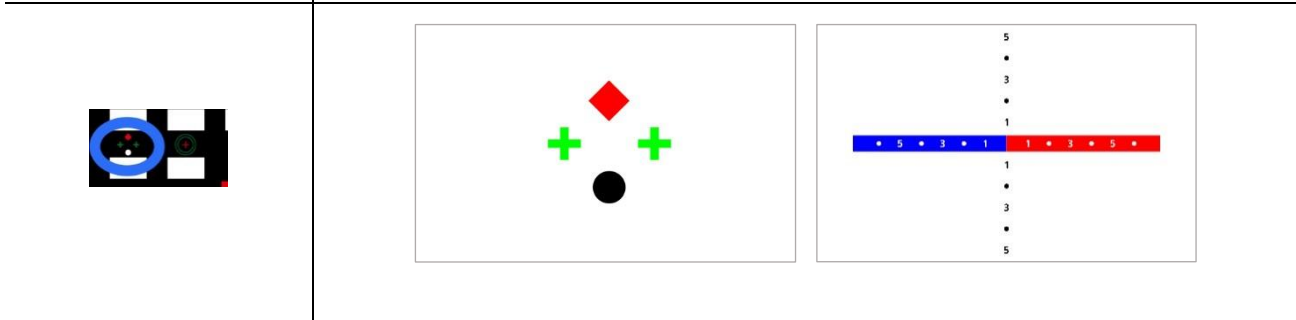
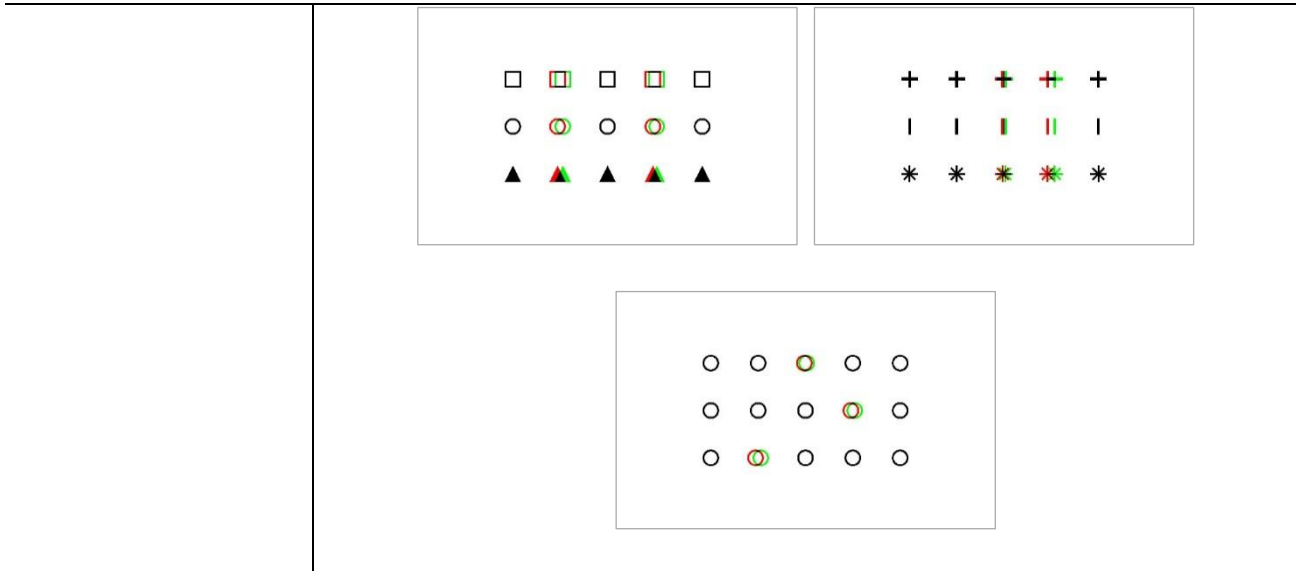

By pressing “Direction movement” button on the remote-control, central red-cross mark can be moved.

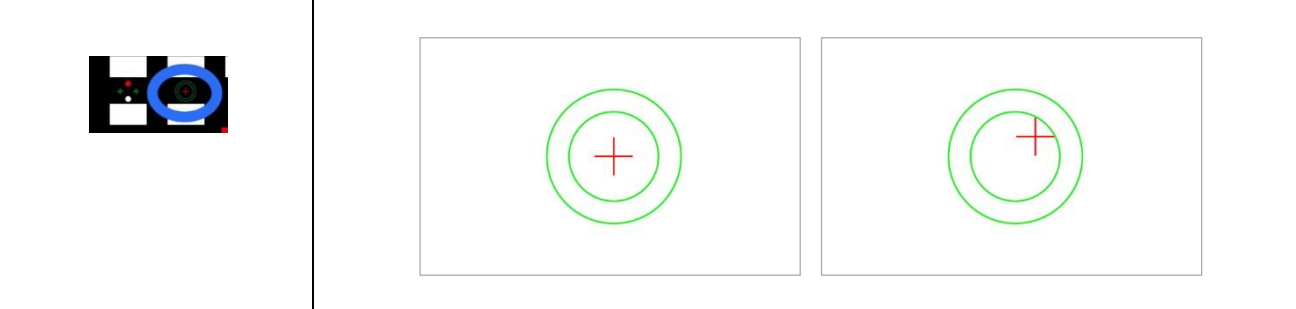

By pressing “Screen reverse function” button on the remote-control, the color between charts and background is changed. Make the best use of this function according to refraction environment.

Tips!

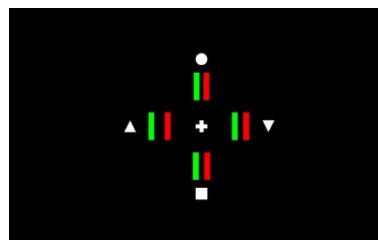
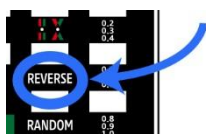

8.5 Color blindness test

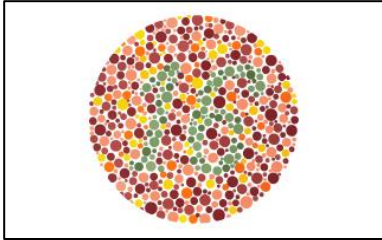
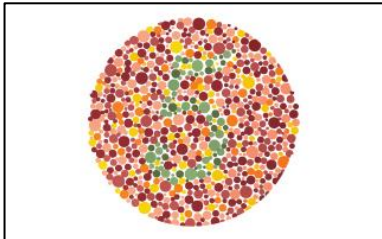
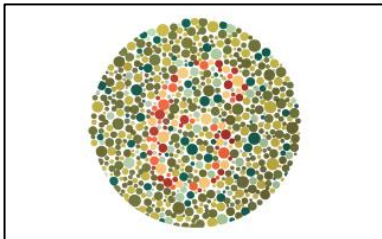
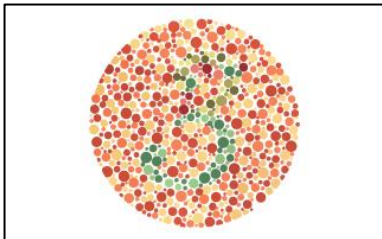
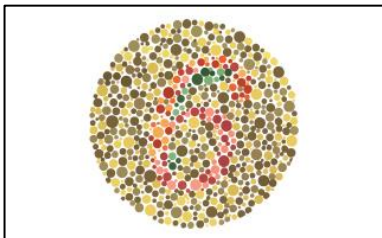
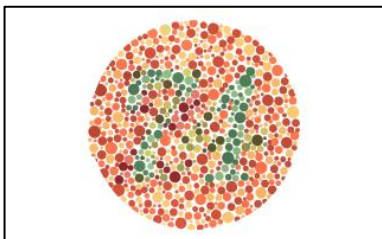
		<p>Normal: 16</p> <p>R/G deficiencies: unreadable</p>
		<p>Normal: 5</p> <p>R/G deficiencies: unreadable</p>
		<p>Normal: 6</p> <p>R/G deficiencies: 5</p>
		<p>Normal: 3</p> <p>R/G deficiencies: 5</p>
		<p>Normal: 6</p> <p>R/G deficiencies: unreadable</p>
		<p>Normal: 74</p> <p>R/G deficiencies: 21</p>

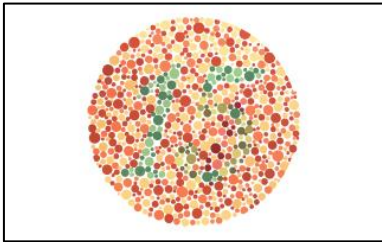
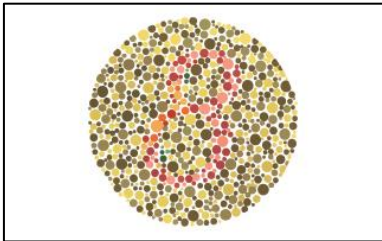
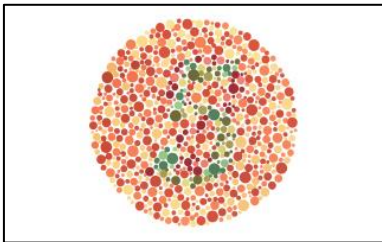
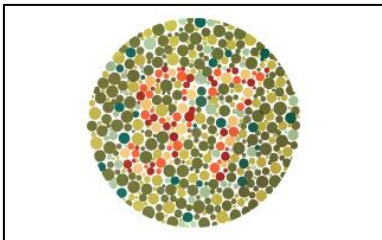
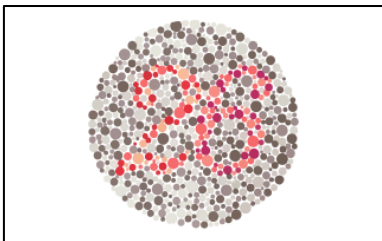
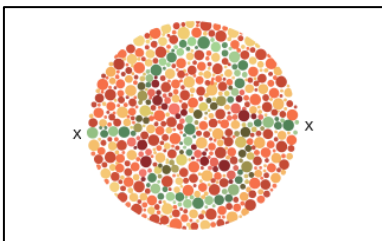
	<p>Normal: 15 R/G deficiencies: 17</p>
	<p>Normal: 8 R/G deficiencies: 3</p>
	<p>Normal: 5 R/G deficiencies: 2</p>
	<p>Normal: 97 R/G deficiencies: unreadable</p>
	<p>Normal: 26 Protanopia: 6 Protanomaly: 6 or 2 Deuteranopia: 2 Deuteranomaly: 2 or 6</p>
	<p>Normal: following green line R/G deficiencies: unrecognized</p>

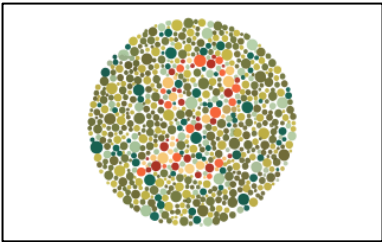
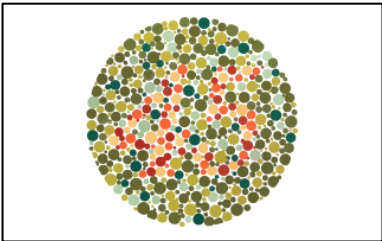
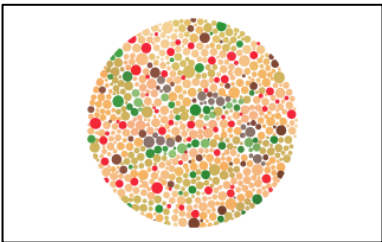
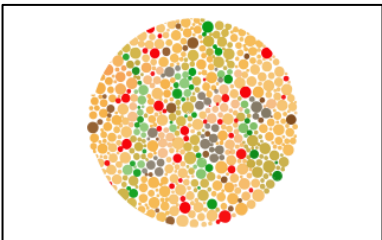
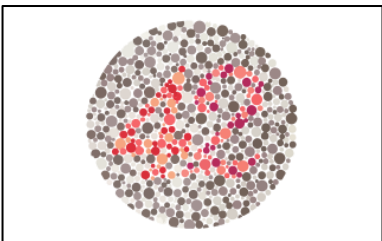
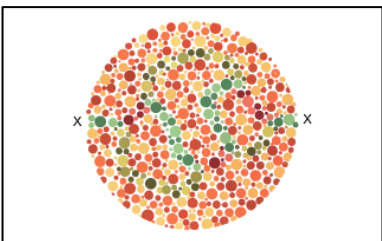
	<p>Normal: 2 R/G deficiencies: unreadable</p>
	<p>Normal: 45 R/G deficiencies: unreadable</p>
	<p>Normal: unreadable R/G deficiencies: any number</p>
	<p>Normal: unreadable R/G deficiencies: following green and purple lines</p>
	<p>Normal: 42 Protanopia: 2 Protanomaly: 2 or 4 Deuteranopia: 4 Deuteranomaly: 4 or 2</p>
	<p>Normal: following green line R/G deficiencies: following green and purple lines</p>

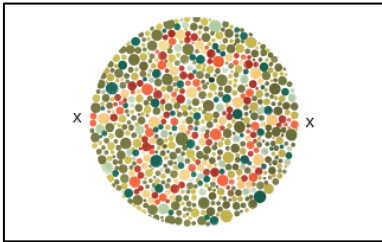
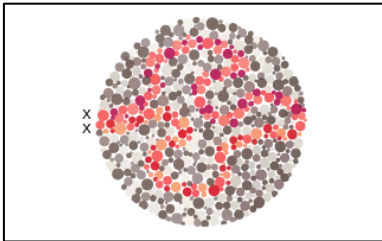
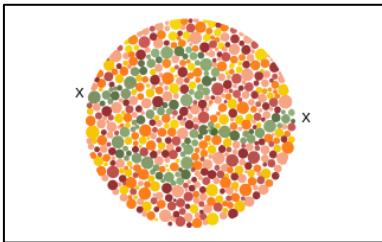
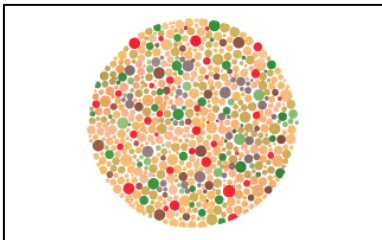
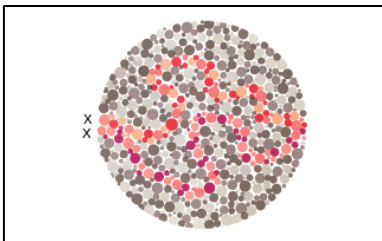
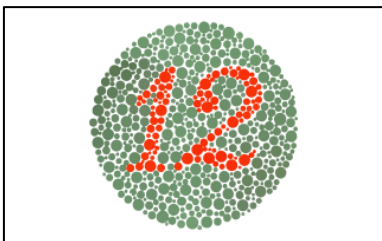
	<p>Normal: unrecognized R/G deficiencies: following line</p>
	<p>Normal: following purple and red lines Protanopia: following purple line only Protanomaly: following purple line only Deuteranopia: following red line only Deuteranomaly: following red line only</p>
	<p>Normal: following green line R/G deficiencies: unrecognized</p>
	<p>Normal: unrecognized R/G deficiencies: following line</p>
	<p>Normal: following purple and red lines Protanopia: following purple line only Protanomaly: following purple line only Deuteranopia: following red line only Deuteranomaly: following red line only</p>
	<p>Normal: 12 R/G deficiencies: 12</p>

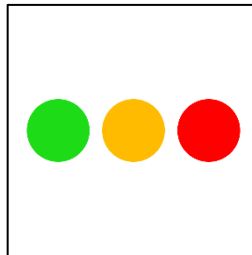
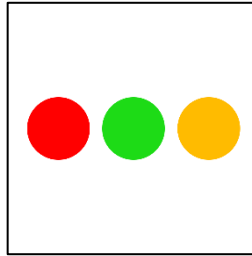
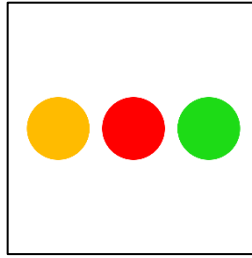
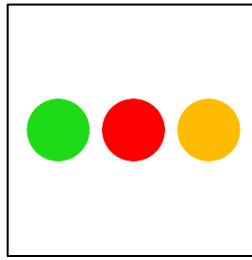

8.6 ETDRS



By pressing “ETDRS” button again on the remote-control, chart type is changed sequentially.





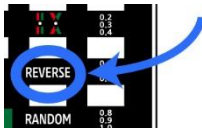

Tips!

By pressing “Screen reverse function” button on the remote-control, the color between charts and background is changed. Make the best use of this function according to refraction environment.

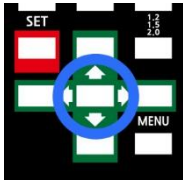

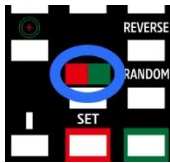
8.7 Contrast sensitivity

	<p>By pressing a button located center of direction movement buttons, the contrast of visual acuity chart can be adjusted.</p> <div style="display: flex; justify-content: space-around;"> <div data-bbox="598 448 981 689">  </div> <div data-bbox="1050 448 1436 689">  </div> </div>
	<p>By pressing "Red/Green Mask" button, the contrast of visual acuity chart can be restored to 100%.</p> <div style="display: flex; justify-content: space-around;"> <div data-bbox="598 907 981 1149">  </div> <div data-bbox="1050 907 1436 1149">  </div> </div>

9 Program function

9.1 Set

(1) Press ► button on the remote-control. Program number (from P1 to P5) will be displayed on the top of screen.

By pressing ◀ or ► button, choose program number.



(2) Press PROGRAM button. "START" message will be displayed on the top of screen.



(3) Press ◀ or ► button. Chart number will be displayed on the top of screen. By pressing ◀ or ► button, choose chart number.



(4) Using the remote-control, display any chart to be stored by program.

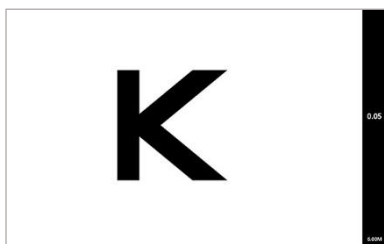

(5) Press SET button to store into program.

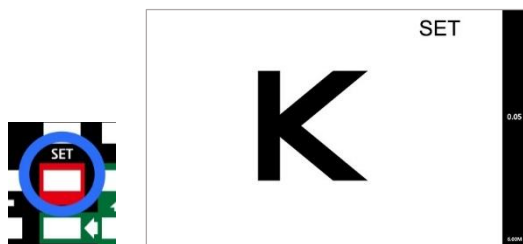

(6) Press ► button to change the chart number.

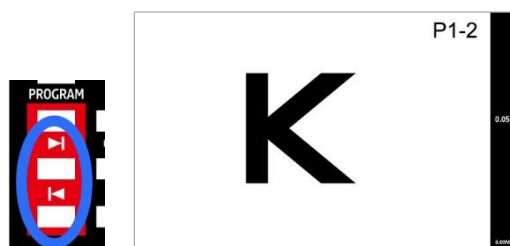

(7) Using the remote-control, display any chart to be stored by program.

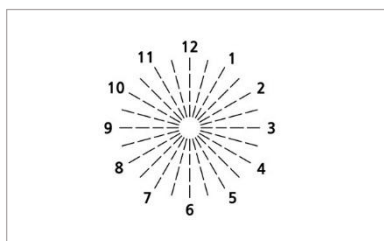

(8) Press SET button to store into program.

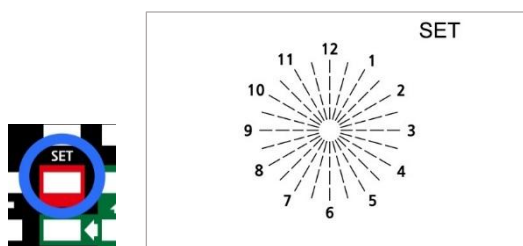

(9) Carry out the process as above description from (5) to (7) repeatedly until chart number 10.

(10) Press PROGRAM button to escape.

9.2 Use

(1) Press ► button on the remote-control. Program number (from P1 to P5) will be displayed on the top of screen.

By pressing ◀ or ▶ button, choose program number.

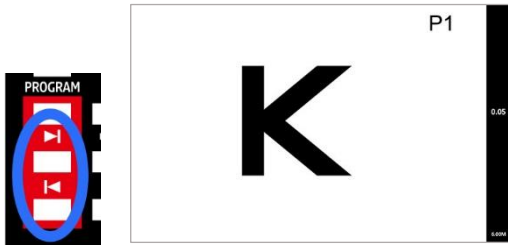

(2) Press PROGRAM button. "START" message will be displayed on the top of screen.

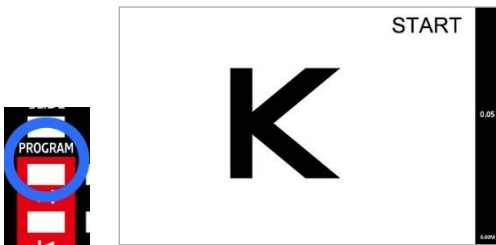

(3) Press ◀ or ▶ button. Chart number will be displayed on the top of screen. By pressing ◀ or ▶ button, choose chart number.

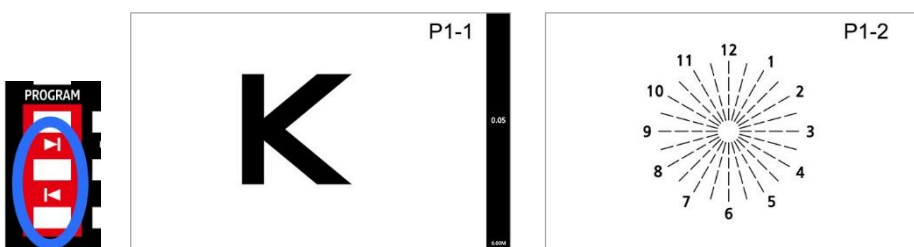

(4) If ◀ or ▶ button is pressed, charts stored in program are displayed sequentially with chart number on the screen.

10 Slide function

(1) Press “Image slide function” button on the remote-control. By pressing “Direction movement” buttons, images can be changed and displayed on the screen.

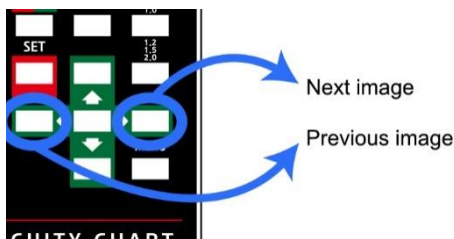

(2) If “Image slide function” button is pressed again, other type of slide image or video will be displayed on the screen.

Default image

Display basic images stored in internal flash memory by manufacturer.

Imported image

Display images stored in internal flash memory by operator.







Imported video

Play videos stored in internal flash memory by operator.

	Some of images cannot be displayed due to not-supported image format.
	Some of videos cannot be played due to not-supported video format.
	For detailed function of slide, consult with manufacturer or authorized local distributor.

11 Maintenance

11.1 Malfunction warnings

	If the screen shows abnormal flickering, distorted optotypes, or unexpected brightness changes, stop using the device immediately and restart the system. If the issue persists, contact service personnel.
	If the device emits unusual smell, heat, or noise, turn off the power and unplug the unit.
	If the remote control becomes completely unresponsive after battery replacement, do not continue the examination until the cause is identified.
	If the displayed chart does not correspond to the remote-control image, discontinue operation until synchronization is restored.
	Do not attempt to open, modify, or repair the device on your own.
	During exposure to strong electromagnetic interference, temporary display flickering, automatic system reboot, or momentary system freezing may occur. In such cases, normal operation is restored after restarting the system or reconnecting the power supply.





11.2 Troubleshooting

In the event that the device does not work correctly, please check the problem according to the following table before contact manufacturer or authorized local distributor.

Event	Recommended action
The screen does not light up even though the power is on.	Check that the power cord is connected firmly to a socket outlet.
The chart is displayed improperly on the screen.	Switch off the device. After 3 minutes, turn it on again.
The remote control does not work.	Replace the batteries in the remote control.
The remote control does not work even though the batteries are replaced.	Set the correct channel of the remote control.
The image on the remote control does not match the display screen.	Unplug the power cord, wait 10 seconds, and plug it in again.
The chart is blurry.	Adjust the brightness or backlight level properly.
The screen is unclear.	Clean the display surface with a soft, dry cloth.
Temporary screen flickering, unresponsive operation, or unexpected restart.	Turn off the device, disconnect the power cord for at least 10 seconds, then reconnect and restart the system.

11.3 Environmental & external influence precautions

- MDR 23.4 (s) compliance

	Avoid using the device in environments with excessive electromagnetic fields (e.g., MRI rooms, high-powered radio equipment).
	The device may be sensitive to electrostatic discharge (ESD). Avoid touching the IR sensor or screen after building up static electricity.
	Operate the device only within the specified temperature and humidity ranges.
	Avoid strong reflections or glare from external light sources.
	Electromagnetic disturbances such as electrostatic discharge (ESD) or strong RF fields may temporarily affect system operation (e.g., screen flickering or unexpected restart). This does not result in permanent damage, and the device resumes normal operation after power cycling.

11.4 Contra-indications & limitations of use

- No absolute contraindications are known.
- Use with caution in:
 - individuals with photosensitive epilepsy
 - individuals who experience discomfort from bright digital displays
- The device is intended only for displaying visual acuity charts.

It is not intended for diagnosis, treatment, or physiological measurement.

11.5 Biological, radiation, and material safety





- This device contains no medicinal substances, no tissues or cells, and no biological materials.
- This device emits only visible light, not radiation requiring protective measures.
- No CMR substances, endocrine-disrupting materials, or sensitizing materials are present.

11.6 Safe disposal information

- This device contains no sharp components, biological materials, or potentially infectious parts.
- Dispose of the device and its accessories in accordance with local regulations for electrical and electronic equipment waste – WEEE.
- Do not dispose of the device as unsorted municipal waste
- No special biomedical waste precautions are required.

11.7 Cleaning

Avoid touching the screen whenever possible because its surface is specially coated. If the screen becomes dirty, the chart may become difficult to read and see. In such an occurrence, clean the panel.

	Turn the power off and unplug the power cord from a socket outlet before cleaning.
	Wiping with tissue paper may seriously damage the screen
	For cleaning, excessive force or loading may result in failure.
	Do not leave water drops on the device. If the device is splashed with water, immediately wipe with absorbent cotton or a soft cloth.
	Never use an organic solvent such as paint thinner.

- (1) Turn the power off.
- (2) Unplug the power cord from a socket outlet.
- (3) Lightly wipe the screen with a soft and clean cloth or absorbent cotton.

11.8 Minimum hardware, network, and IT security requirements

This device incorporates an electronic programmable system and embedded software. To ensure proper operation and maintain the intended performance of the device, the following minimum requirements and IT security measures shall be observed:

11.8.1 Hardware requirements

- Use only the hardware supplied or approved by the manufacturer.
- Do not modify or replace internal components, firmware, or the operating system.
- Ensure stable power supply (100-240 Vac, 50/60 Hz) and avoid the use of unregulated power adapters.

11.8.2 IT Network requirements

- The device is designed for stand-alone operation and does not require network connectivity for normal clinical use.
- When network access is used (e.g., software update, service diagnostics), the network must comply with standard clinical IT infrastructure requirements:
 - Use of secured networks (e.g., WPA2/WPA3)
 - Restriction of unauthorized devices and public networks
 - Controlled access by authorized persons only

11.8.3 IT security measures

- The device must be protected against unauthorized access, modification, or installation of unverified software.
- Only manufacturer-approved software updates shall be installed.
- Do not connect the device to unsecured network environments.
- Access to system settings should be limited to authorized personnel.
- Maintain physical security to prevent tampering.

12 Transport and storage conditions

Temperature	-10 °C to +40 °C
Relative Humidity	10 % to 90 % (non-condensing)
Atmospheric pressure	80 kPa to 106 kPa

When storing the product, ensure that the following conditions:

- It shall not be splashed with water.
- Store the product away from environments where air pressure, temperature, humidity ventilation sunlight, dust, salty/sulfurous air, etc. could cause damage.
- Do not store or transport the instrument on a slanted or uneven surface or in an area where it is subject to vibrations or instability.
- Do not store the instrument where chemicals are stored or gas is generated.



Do not store or use in place with the following conditions:

- harmful gases or polluted air;
- blowing dust or sand;
- easy exposure to oil residue or fuel elements;
- atmosphere that has above standard levels of salt;
- prone to dust collecting;
- floor surface with a slope higher than 10°;
- voltage from wall sockets is changing severely;
- exposure to direct sunlight.

13 Detailed specifications

13.1 General

Display	24inch WUXGA TFT LCD (1920 x 1200 pixels)
Active display area	(W)518.4 x (H)324.0 mm (W)20.4 x (H)12.8 inches
Brightness	Maximum 300cd/m ²
Measuring distance	1.5 - 8.0m (0.1m step) 4.75 – 26 feet (0.25 feet step)
CPU	Amlogic S905 SoC 4 x ARM Cortex-A53 1.5GHz 64bit ARMv8 Architecture @28nm
GPU	3 x ARM Mali-450 MP 700MHz
Memory	SD Memory 32GB 90MB/s
Operating system	Android Open Source Project (AOSP)
Power supply	AC 100-240V, 50/60Hz, 60W
Control	Infrared remote-control or serial communication
Multi-control channel	Max 4 channels
External interface	4x USB, 1x RS-232, 1x Ethernet (10/100/1000)
Standard Accessory	Wall mount bracket
Dimension & weight	(W)21 x (H)14 x (D) 1.6 inch / (W)534 x (H)361 x (D)41mm Approximately 8.8 lbs (4 kg)

13.2 Display pixel defect acceptance criteria

This device uses a high-resolution LCD display to present optotypes. To ensure consistent clinical performance, the display panel must meet the following pixel defect acceptance criteria at the time of shipment and during field service evaluation.

The criteria are defined based on:

- ISO 9241-307:2008 (Visual display requirements) – reference standard
- ISO 14971:2019 (Risk management – clinical impact evaluation)
- Manufacturer's internal specification TSC-DMR-001
- MDR Annex I (GSPR 1, 5, 9, 10 – safety & performance)

13.2.1 Definitions

- Pixel: The smallest addressable element on the display, consisting of red, green and blue sub-pixels.
- Sub-pixel: A single color component within a pixel.
- Bright pixel defect: A pixel that remains permanently "on" (visible as a bright dot on a dark background).
- Dark pixel defect: A pixel that remains permanently "off" (visible as a dark dot on a bright background).
- Sub-pixel defect: Only one sub-pixel is stuck on/off while others operate normally.
- Cluster defect: Two or more defective pixels/sub-pixels adjacent in any direction.
- Critical (central) area: The central 25% of the active display area, defined by a 4 × 4 grid.
- Defects in this region are not allowed due to potential impact on visual acuity scoring.

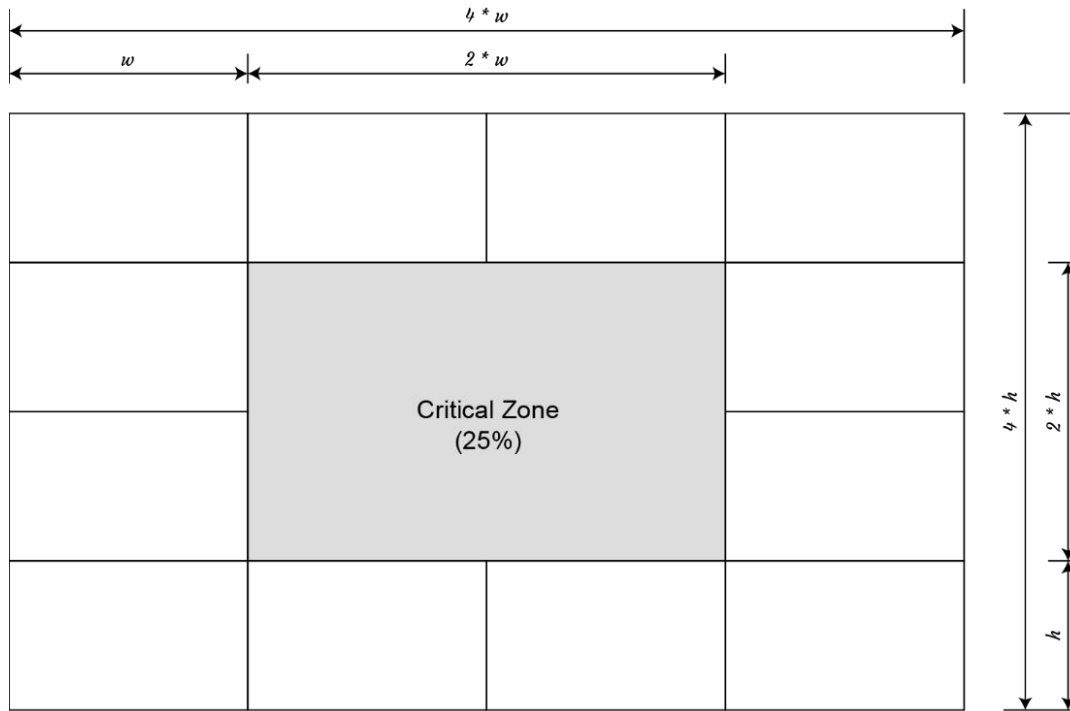

[Critical zone of active display area]

13.2.2 Acceptance criteria

The display shall meet the following defect limits:

No.	Type of defect	Acceptance criteria (per panel)
1	Bright pixel defects	≤ 1
2	Dark pixel defects	≤ 2
3	Sub-pixel defects (isolated)	≤ 3
4	Cluster defects (any type)	Not allowed
5	Any defect in the central 25% area	Not allowed
6	Total number of pixel-related defects	≤ 3 (sum of items 1-3)

Any display exceeding these limits is not accepted for delivery or field use.

13.2.3 Test Conditions

a) Test patterns:

- Full white / full black / full red / full green / full blue / checkerboard.

b) Viewing conditions:

- Ambient illumination: approx. 100 – 300 lux
- Viewing distance: 50 – 70 cm
- Viewing angle: perpendicular to screen center

c) Method:

- Visual inspection by trained personnel in accordance with manufacturer specification TSC-DMR-001.

13.2.4 Rationale for criteria

- The central region of the display is used for optotype presentation; defects in this zone may interfere with accurate visual acuity scoring.
- The allowed defect quantity outside the central area is clinically insignificant and validated through risk management.
- Criteria are stricter than general consumer-grade displays (ISO 9241-307), ensuring compliance with:

MDR Annex I GSPR 1 (safety & performance)

GSPR 5 & 9 (risk reduction as far as possible)

GSPR 10 (protection from physical hazards)

13.2.5 Field service / Post-Market handling

- Customer complaints regarding visual artifacts are evaluated using the same criteria.
- Units exceeding the acceptance limits shall be repaired or replaced per the manufacturer's PMS and vigilance procedures.

14 Regulatory and compliance information

Category	Applicable standard / regulation	Scope	Test / Certification Reference	Status
Safety	IEC 60601-1:2005 +A1:2012 +A2:2020	Medical electrical equipment – General requirements for basic safety and essential performance	Test Report No. M25WD-033 issued by Standard Bank Co., Ltd.	Compliant (Pass)
EMC	IEC 60601-1-2:2014 +A1:2020	Electromagnetic compatibility (emissions / immunity)	Test Report No. SB25-G3074-EM2775 issued by Standard Bank Co., Ltd.	Compliant (Pass)
Usability	IEC 60601-1-6:2020	Collateral standard: Usability	Test Report No. M25WD-033 issued by Standard Bank Co., Ltd.	Compliant (Pass)
Ophthalmic instrument	ISO 15004-1:2020	Fundamental requirements and test method	Test Report No. M25WD-033 issued by Standard Bank Co., Ltd.	Compliant (Pass)
Usability engineering	IEC 62366-1:2015 +A1:2020	Usability engineering process	Usability Engineering File TSC-UE-001	Compliant
Software validation	IEC 62304:2006 +A1:2015 (Class A)	Medical device software life cycle processes	Software Validation Report TSC-SVVP-001	Compliant
Risk management	ISO 14971:2019	Risk management for medical devices	Risk Management File TSC-RMF-001	Compliant

Quality Management system	ISO 13485:2016	Quality management systems for medical devices	QMS Certificate No. 25-b-1983 Rev.0	Certified
EU regulation	[MDR] Regulation (EU) 2017/745	Class I medical device	Declaration of Conformity	CE Marking
Korean regulation	Medical Device Act	Medical device approval	Registry No. 25-881	Approved
Environmental directives	[WEEE] Directive 2012/19/EU	Waste electrical and electronic equipment	WEEE Symbol applied	Compliant
	[ROHS] Directive 2011/65/EU	Restriction of hazardous substances	Material Declaration	Compliant
Power supply	IEC 60601-1, IEC 60601-1-11	GSM60A12 (MEAN WELL) medical power adapter	TÜV Rheinland, CB Certificate	Compliant

15 EMC information

Precaution to be taken to prevent adverse events to the patient and the operator due to Electromagnetic Disturbances are listed in the column “Electromagnetic environment – guidance” in the tables below.

A. Manufacturer announcement – electromagnetic waves trouble

Electromagnetic waves trouble	
TSLC-2000 should be used in the below mentioned electromagnetic wave environment. TSLC-2000 purchaser or user needs to confirm whether it is used in this type of environment.	
Trouble test	Question of appropriateness
RF emissions CISPR 11	Group 1
RF emissions CISPR 11	Class A
Harmonic emissions IEC 61000-3-2	Class A
Voltage fluctuations/flicker IEC 61000-3-3	Complies

B. Manufacturer announcement – electromagnetic waves tolerance

Electromagnetic waves tolerance		
TSLC-2000 is to be used in the below mentioned electromagnetic wave environment. TSLC-2000 purchaser or user needs to confirm whether it issued at this environment.		
Tolerance test	IEC 60601 test conditions	Appropriateness level
Electrostatic discharge (ESD) IEC 61000-4-2	contact ± 8 kV in the air ± 15 kV	contact ± 8 kV in the air ± 15 kV
Electric rapid transients/burst IEC 61000-4-4	power supplying line ± 2 kV input/output line ± 1 kV	power supplying line ± 2 kV input/output line ± 1 kV
Surge IEC 61000-4-5	between lines ± 1 kV between line and grounding ± 2 kV	differential mode ± 1 kV common mode ± 2 kV
Voltage dip, instantaneous interruption, voltage fluctuation at the power input line IEC 61000-4-11	for 0.5 cycle $< 5\%$ UT (UT's $>95\%$ decrease) for 5 cycle 40% UT (UT's 60% decrease)	for 0.5 cycle $< 5\%$ UT (UT's $>95\%$ decrease) for 5 cycle, 50% UT (UT's 60% decrease)

	for 25 cycle 70% UT (UT's 30% decrease) for 5 seconds < 5% UT (UT's > 95% decrease)	for 25 cycle, 70% UT (UT's 30% decrease) for 5 seconds, <5% UT (UT's > 95% decrease)
Power frequency magnetic field (50/60 Hz) IEC 61000-4-8	30 A/m	30A/m
Other UT is the a.c. power voltage for before approving the test level.		
Conductivity RF electromagnetic field IEC 61000-4-6	3 Vrms 150 kHz – 80 Mhz 5 Vrms in ISM band 6.765 MHz to 6.795 MHz 13.553 MHz to 13.567 MHz 26.957 MHz to 27.283 MHz 40.66 MHz to 40.70 MHz	3 Vrms 6 Vrms
Radioactivity RF electromagnetic field tolerance IEC 61000-4-3	3 V/m 80 MHz – 2.7 GHz scope	3 V/m

16 Revision history

No.	Date	Contents
0	2025.09.22	- Initial
1	2025.10.30	- Added 1.2 Device name and model - Added 1.6 Authorised Representative in EU - Added Operating environment in 2.2 Intended environment
2	2025.11.25	- Added 1.4 Qualification of the product as medical device
3	2025.12.10	- Added 2.4 Residual risks - Added 2.5 Indications
4	2025.12.14	- Added 2.6 Contra-indications - Added 2.7 Patient target groups - Added 2.8 Undesirable side-effects - Added 2.9 Operating principle - Added 2.9.1 Mode of action - Added 2.9.2 Scientific basis - Added 3.1 Reporting of Serious Incidents
5	2025.12.30	- Added 11.1 Malfunction warnings - Added 11.3 Environmental & external influence precautions - Added 11.4 Contra-indications & limitations - Added 11.5 Biological, radiation, and material safety - Added 11.6 Safe disposal information - Added 11.8 Minimum hardware, network, and IT security requirements
6	2026.01.10	- Added 6.4 Outer Packaging - Added 13.2 Display pixel defect acceptance criteria
7	2026.01.31	- Changed 1.6 Authorized Representative
8	2026.02.10	- Changed 4.3 Accessories - Changed 6.4 Outer Packaging
9	2026.04.09	- Added 15 EMC information - Added 16 Revision history